

Esense Fixed - Electric Drive Castor Wheel: Plate, 142mm dia, 600kg Load

Product code: ESFIXEDPD/SH/9AH

Transform heavy lifting into healthy movement with the Esense Fixed. This is an electric drive fixed castor wheel (142mm) from the Esense range. Ideal for indoor use on solid, industrial surfaces.

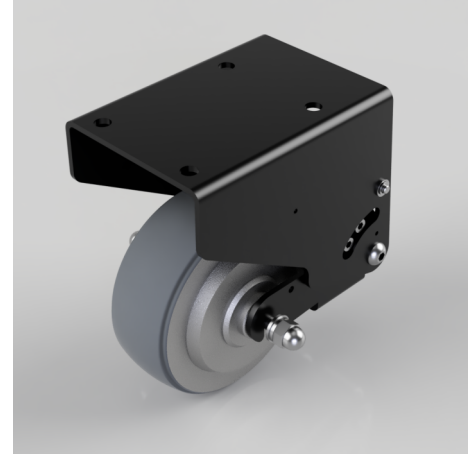

- Reduce effort: Power-assisted forward & backwards driving
- Rechargeable battery with auto switch-off function
- Simple to use & move with the sensor handles
- Water resistant connectors
- 600kg load capacity

Wheel Material	Polyurethane on Aluminium
Diameter (mm)	142
Tread (mm)	43
Colour / Shore Hardness	Black Polyurethane on Aluminium Rim / 64 Shore A
Temperature Resistance	-20°C - 50°C Driving, 10°C - 40°C Charging
Load Capacity (kg)	600
Height (mm)	160 - 210
Plate Size (mm)	120 x 170
Hole Centres (mm)	105 x 120
Max Speed	6km/h
Battery	24V 9Ah
Charge Time	4.5hr
Wheel Torque	Max 15Nm
Threshold (mm)	20

BIL GROUP LTD

Porte Marsh Road, Calne, Wiltshire, SN11 9BW

Registered in England No: 2603821

VAT Reg: GB572705729

