

Nylon Plate Fixed Castor 100mm 600kg Load

Product code: BZJF100NYBJ/USA

Fabricated fixed castor with a top plate fixing fitted with a white nylon wheel with ball bearings. Wheel diameter 100mm, tread width 40mm, overall height 143mm, top plate 115mm x 102mm, hole centres 92mm x 67mm and 76mm x 76mm Load capacity 600kg.

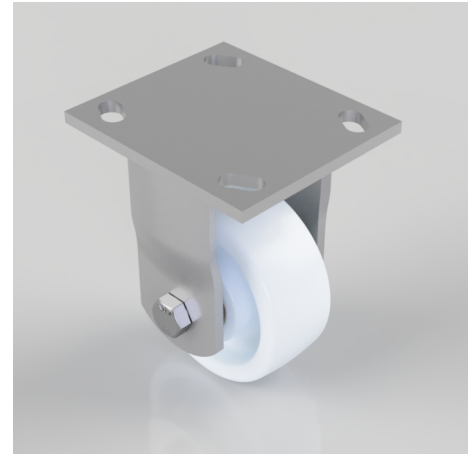

Diameter (mm)	100
Fixing Option	Plate
Castor Type	Fixed
Bearing Type	Ball
Height (mm)	143
Plate Size (mm)	115 x 102
Hole Centres (mm)	76/92 x 76/67
To Suit Fixing Bolt (mm)	10
Wheel Material	Nylon
Colour / Shore Hardness	White Nylon
Temperature Resistance	-30 °C TO +80 °C
Top Plate Thickness (mm)	5.5
Fork Thickness (mm)	5.5
Load Capacity (kg)	600
Tread (mm)	40