

Nylon Plate Fixed Castor 125mm 200kg Load

Product code: BZMMF125NYBJ

Pressed steel fixed castor with a top plate fixing fitted with a white nylon wheel with single ball bearing and hub caps. Wheel diameter 125mm, tread width 37mm, overall height 155mm, plate size 105mm x 85mm, hole centres 80mm x 60mm. Load capacity 200kg.

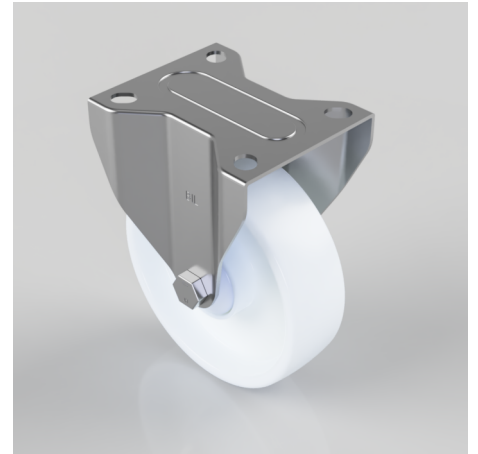

Diameter (mm)	125
Castor Type	Fixed
Fixing Option	Plate
Height (mm)	155
Wheel Material	Nylon
Colour / Shore Hardness	White Nylon
Temperature Resistance	-30 °C TO +80 °C
Bearing Type	Ball
Load Capacity (kg)	200
Tread (mm)	37
Plate Size (mm)	105 X 85
Hole Centres (mm)	80 X 60
Top Plate Thickness (mm)	2
Fork Thickness (mm)	2
To Suit Fixing Bolt (mm)	8

BIL GROUP LTD

Porte Marsh Road, Calne, Wiltshire, SN11 9BW

Registered in England No: 2603821

VAT Reg: GB572705729

