

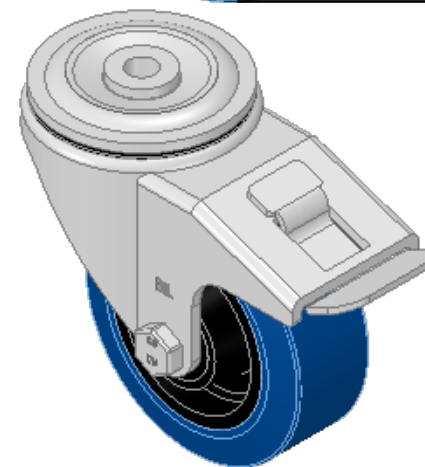

DRAWING DISCLAIMER
 COPYRIGHT OF THIS DRAWING IS RESERVED BY BIL GROUP LTD. IT IS ISSUED ON CONDITION THAT IT IS NOT REPRODUCED, COPIED, OR DISCLOSED TO A THIRD PARTY EITHER WHOLLY OR IN PART WITHOUT THE CONSENT IN WRITING OF BIL GROUP LTD.

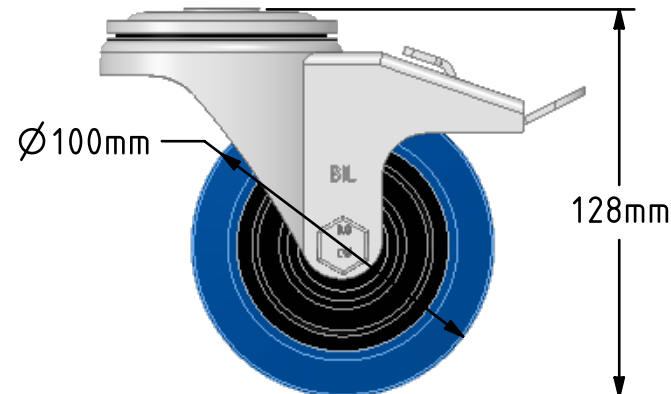
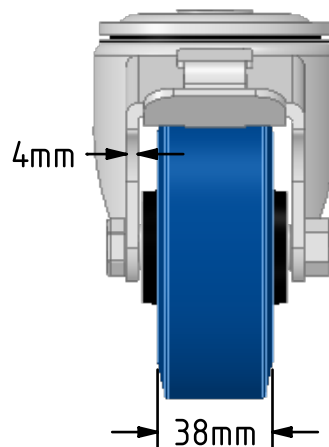
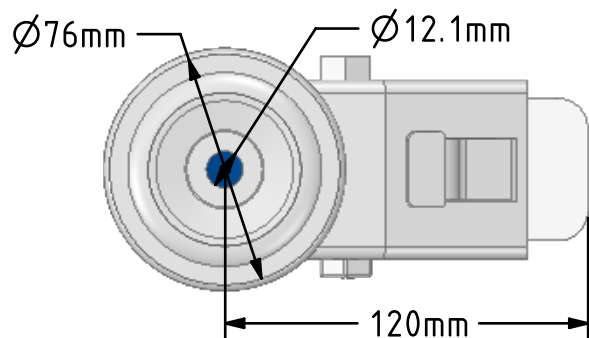
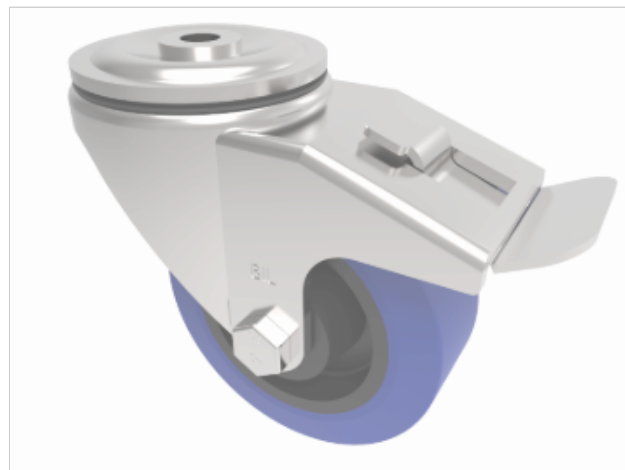

Description:
 BZH100RNBBH12SWB

Pressed steel swivel castor with a 12mm bolt hole fixing fitted with a blue 75 shore A elastic rubber tyre on black nylon centred wheel with a roller bearing and total lock brake. Wheel diameter 100mm, tread width 38mm, overall height 128mm. Load capacity 250kg.



	NAME	DATE	BIL Group Ltd, Porte Marsh Road, Calne Wiltshire, SN11 9BW, United Kingdom Tel +44 (0)1249 822 222 Fax: +44 (0)1249 822 300 www.bilgroup.co.uk	
DRAWN	Matt	24/10/18	 TITLE BZH100RNBBH12SWB	
APPROVED BY	Tim W	24/10/18		
SCALE	2.5	24/10/18		
WEIGHT	1.17kg	24/10/18		
UNLESS OTHERWISE SPECIFIED DIMENSIONS ARE IN MILLIMETRES			SIZE	DWG NO.
Unspecified Tolerances Machining ± 0.25mm Fabrication ± 1mm			A4	BILCW03BZH100RNBBH12SWB_02
			REV	2
			FILE NAME BILCW03BZH100RNBBH12SWB_02.PDF SHEET 1 OF 1	