

DRAWING DISCLAIMER
 COPYRIGHT OF THIS DRAWING IS RESERVED BY BIL GROUP LTD. IT IS ISSUED ON CONDITION THAT IT IS NOT REPRODUCED, COPIED, OR DISCLOSED TO A THIRD PARTY EITHER WHOLLY OR IN PART WITHOUT THE CONSENT IN WRITING OF BIL GROUP LTD.

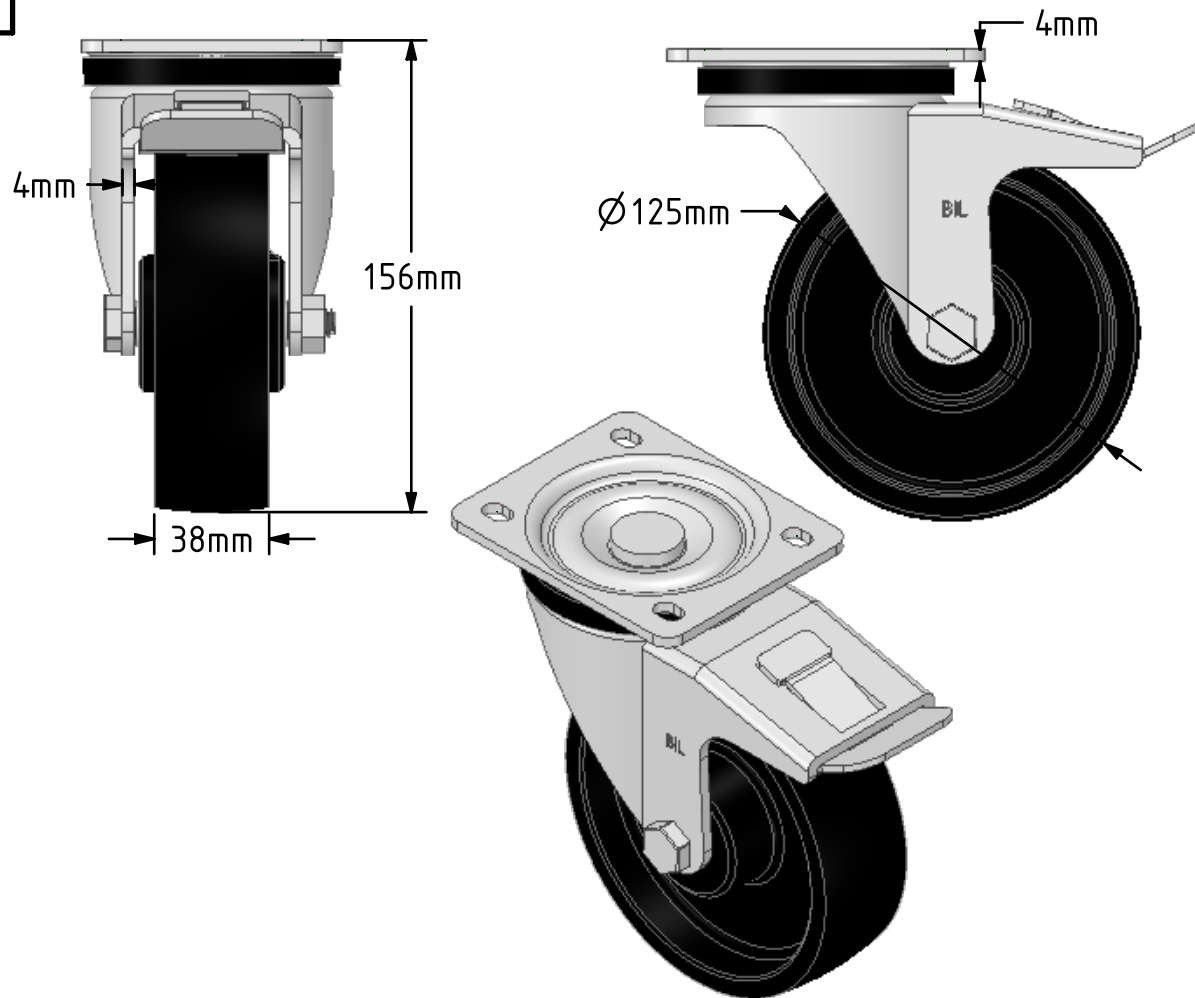

Description:
BZH125CISWB

Pressed steel swivel castor with a top plate fixing with a cast iron wheel with plain bearing and total lock brake. Wheel diameter 125mm, tread width 38mm, overall height 156mm, top plate 105mm x 86mm, hole centres 80mm x 60mm. Load capacity 350kg.

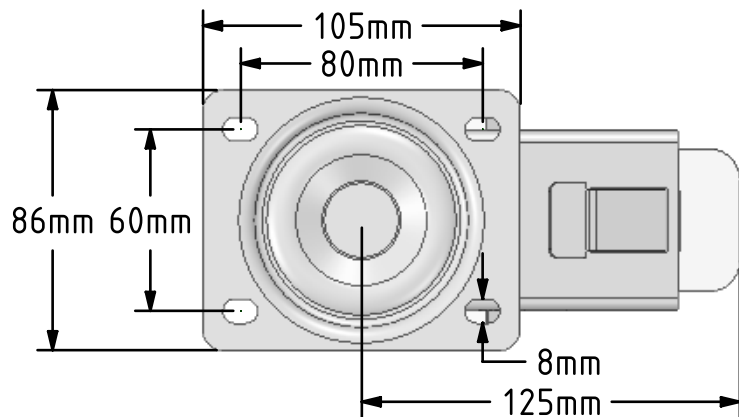

	NAME	DATE
DRAWN	Matt	25/03/19
APPROVED BY	Chris	25/03/19
SCALE	2.5	25/03/19
WEIGHT	2.367kg	25/03/19

UNLESS OTHERWISE SPECIFIED DIMENSIONS ARE IN MILLIMETRES
 Unspecified Tolerances
 Machining ± 0.25mm
 Fabrication ± 1mm

 BIL Group Ltd, Porte Marsh Road, Calne Wiltshire, SN11 9BW, United Kingdom Tel +44 (0)1249 822 222 Fax: +44 (0)1249 822 300 www.bilgroup.co.uk		TITLE	
		BZH125CISWB	
SIZE	DWG NO.	REV	
A4	BILCW03BZH125CISWB_01	1	
FILE NAME	BILCW03BZH125CISWB_01.PDF		SHEET 1 OF 1