

DRAWING DISCLAIMER
 COPYRIGHT OF THIS DRAWING IS RESERVED BY BIL GROUP LTD. IT IS ISSUED ON CONDITION THAT IT IS NOT REPRODUCED, COPIED, OR DISCLOSED TO A THIRD PARTY EITHER WHOLLY OR IN PART WITHOUT THE CONSENT IN WRITING OF BIL GROUP LTD.

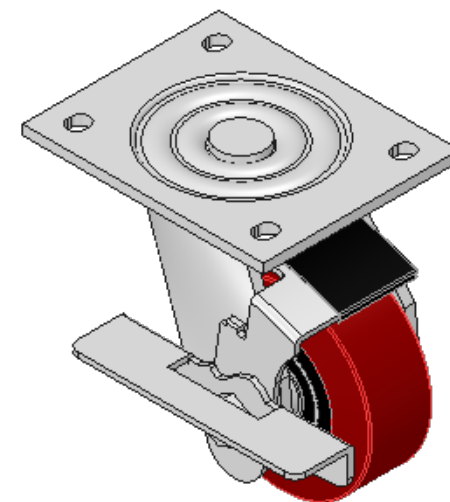

Description:
 BZJ100PTBJBK

Fabricated swivel castor with a top plate fixing fitted with a polyurethane wheel on a cast iron centre with ball bearings and side mounted wheel brake. Wheel diameter 100mm, tread width 40mm, overall height 143mm, top plate 135mm x 110mm, hole centres 105mm x 80mm. Load capacity 300kg.

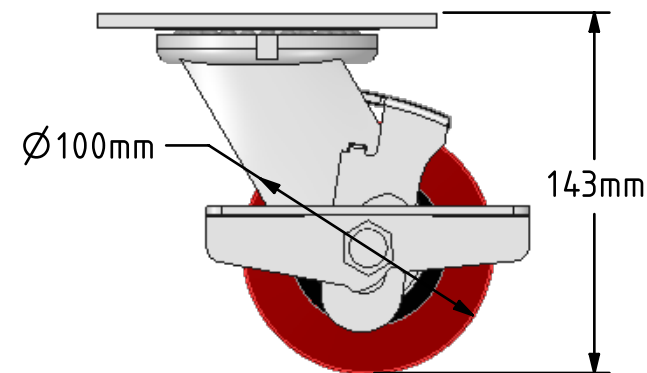
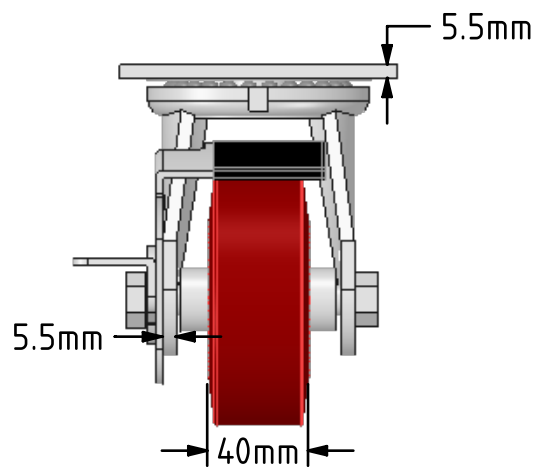
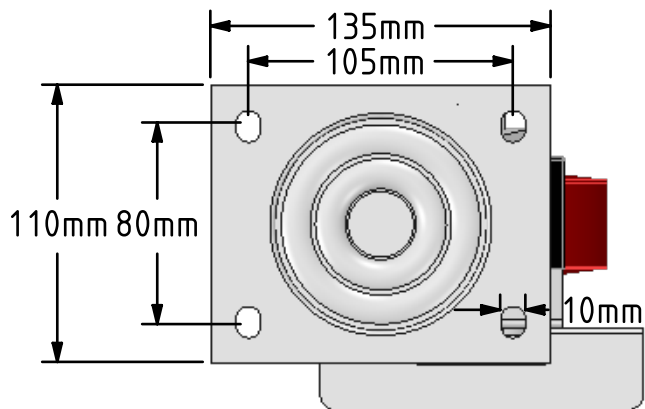

	NAME	DATE
DRAWN	Matt	09/04/18
APPROVED BY	Chris	09/04/18
SCALE	1:3	09/04/18
WEIGHT	2.837kg	09/04/18

UNLESS OTHERWISE SPECIFIED DIMENSIONS ARE IN MILLIMETRES

Unspecified Tolerances
 Machining ± 0.25mm
 Fabrication ± 1mm



BIL Group Ltd, Porte Marsh Road, Calne
 Wiltshire, SN11 9BW, United Kingdom
 Tel +44 (0)1249 822 222 Fax: +44 (0)1249 822 300
 www.bilgroup.co.uk

TITLE

BZJ100PTBJBK

SIZE DWG NO.

A4

BILCW03BZJ100PTBJBK_01

REV

1

FILE NAME

BILCW03BZJ100PTBJBK_01.PDF

SHEET 1 OF 1