

DRAWING DISCLAIMER
 COPYRIGHT OF THIS DRAWING IS RESERVED BY BIL GROUP LTD. IT IS ISSUED ON CONDITION THAT IT IS NOT REPRODUCED, COPIED, OR DISCLOSED TO A THIRD PARTY EITHER WHOLLY OR IN PART WITHOUT THE CONSENT IN WRITING OF BIL GROUP LTD.

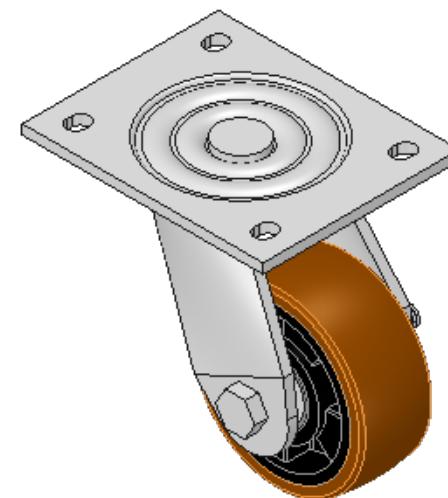

Description:
 BZJ100XPNB

Fabricated swivel castor with a top plate fixing fitted with a brown polyurethane tyred black nylon centred wheel with ball bearings. Wheel diameter 100mm, tread width 40mm, overall height 143mm, top plate 135mm x 110mm, hole centres 105mm x 80mm. Load capacity 300kg.

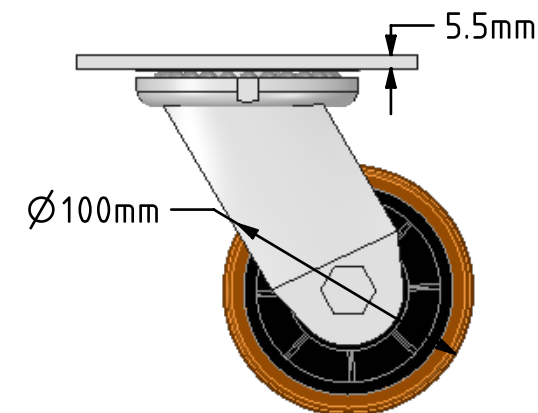
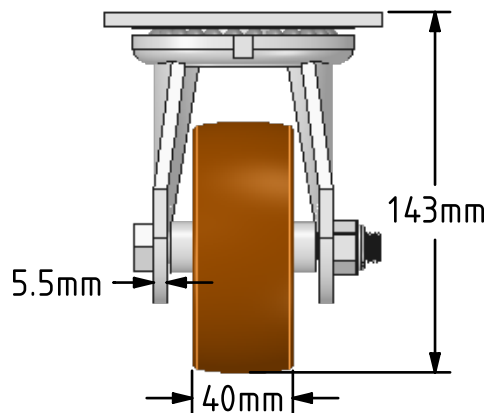
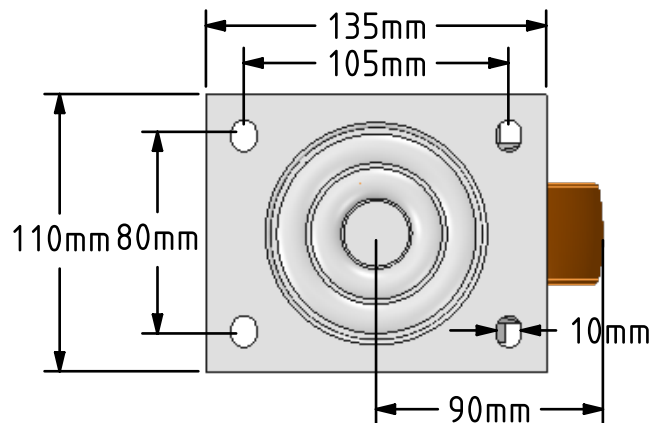

	NAME	DATE
DRAWN	Matt	05/04/18
APPROVED BY	Chris	05/04/18
SCALE	1:3	05/04/18
WEIGHT	2.082kg	05/04/18

UNLESS OTHERWISE SPECIFIED DIMENSIONS ARE IN MILLIMETRES
 Unspecified Tolerances
 Machining ± 0.25mm
 Fabrication ± 1mm

BIL BIL Group Ltd, Porte Marsh Road, Calne Wiltshire, SN11 9BW, United Kingdom
 Tel +44 (0)1249 822 222 Fax: +44 (0)1249 822 300
 www.bilgroup.co.uk

TITLE		REV
BZJ100XPNB		1
SIZE	DWG NO.	FILE NAME
A4	BILCW03BZJ100XPNB_01	BILCW03BZJ100XPNB_01.PDF
		SHEET 1 OF 1