

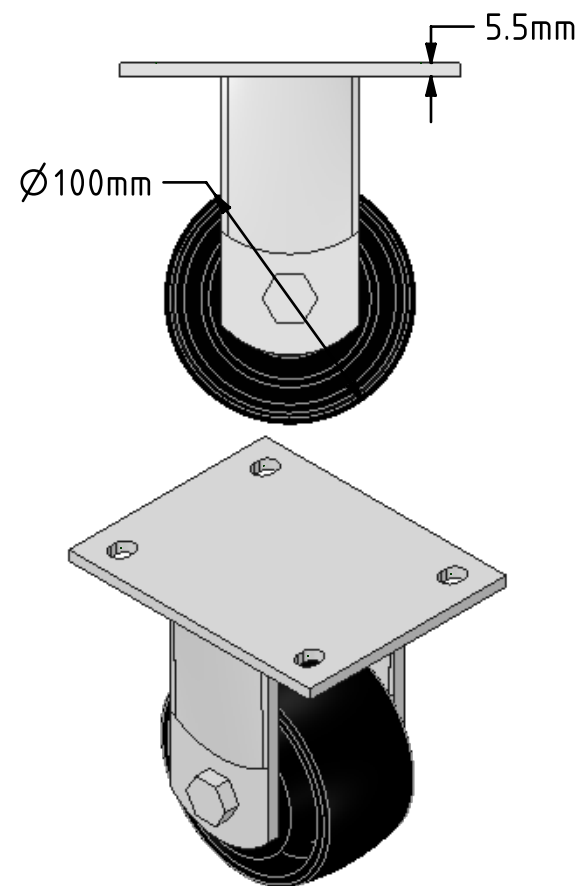

DRAWING DISCLAIMER
 COPYRIGHT OF THIS DRAWING IS RESERVED BY BIL GROUP LTD. IT IS ISSUED ON CONDITION THAT IT IS NOT REPRODUCED, COPIED, OR DISCLOSED TO A THIRD PARTY EITHER WHOLLY OR IN PART WITHOUT THE CONSENT IN WRITING OF BIL GROUP LTD.

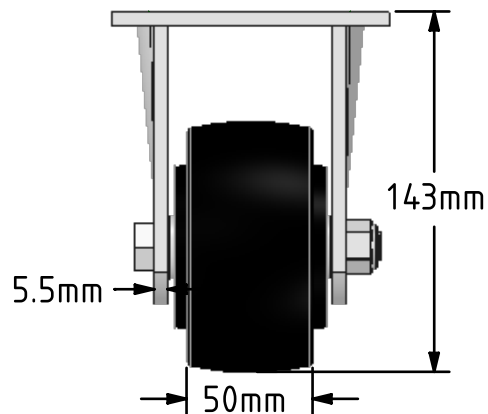
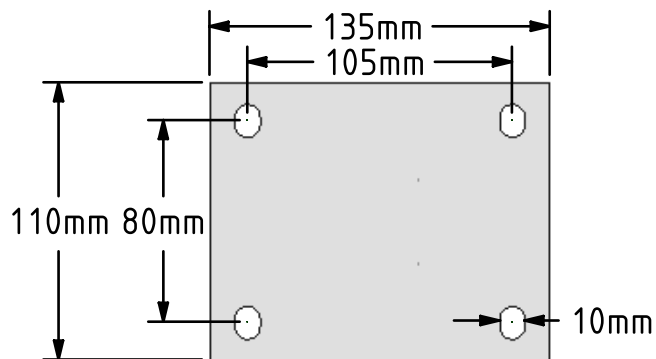

Description:
 BZJF100CIBJ

Fabricated fixed castor with a top plate fixing fitted with a black cast iron wheel with ball bearings. Wheel diameter 100mm, tread width 50mm, overall height 143mm, top plate 135mm x 110mm, hole centres 105mm x 80mm. Load capacity 400kg.



	NAME	DATE	BIL Group Ltd, Porte Marsh Road, Calne Wiltshire, SN11 9BW, United Kingdom Tel +44 (0)1249 822 222 Fax: +44 (0)1249 822 300 www.bilgroup.co.uk	
DRAWN	Matt	29/03/18	 TITLE BZJF100CIBJ	
APPROVED BY	Tim W	29/03/18		
SCALE	1:3	29/03/18		
WEIGHT	3.326kg	29/03/18		
UNLESS OTHERWISE SPECIFIED DIMENSIONS ARE IN MILLIMETRES			SIZE	DWG NO.
Unspecified Tolerances Machining ± 0.25mm Fabrication ± 1mm			A4	BILCW03BZJF100CIBJ_01
			REV	1
			FILE NAME	BILCW03BZJF100CIBJ_01.PDF SHEET 1 OF 1