

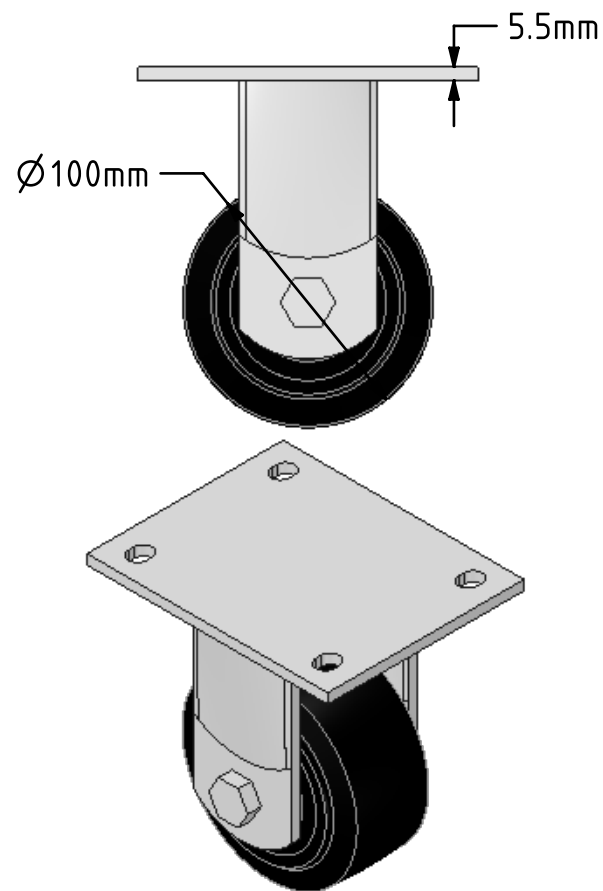

DRAWING DISCLAIMER
 COPYRIGHT OF THIS DRAWING IS RESERVED BY BIL GROUP LTD. IT IS ISSUED ON CONDITION THAT IT IS NOT REPRODUCED, COPIED, OR DISCLOSED TO A THIRD PARTY EITHER WHOLLY OR IN PART WITHOUT THE CONSENT IN WRITING OF BIL GROUP LTD.

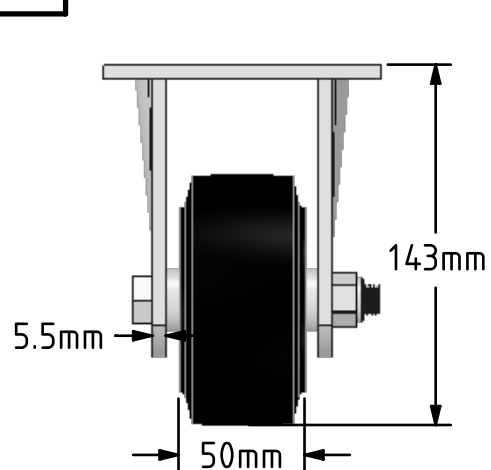
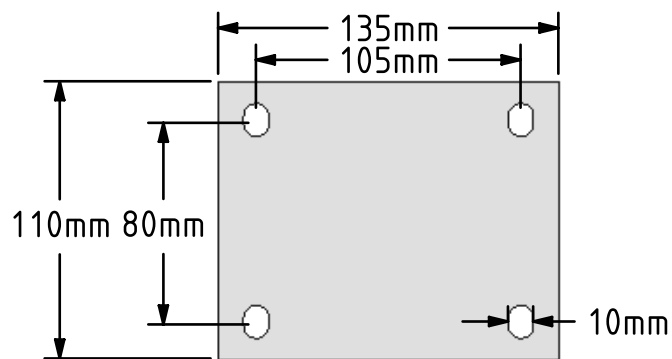

Description:
 BZJF100CRBJ

Fabricated fixed castor with a top plate fixing fitted with a black elastic rubber on black cast iron centred wheel with ball bearings. Wheel diameter 100mm, tread width 50mm, overall height 143mm, top plate 135mm x 110mm, hole centres 105mm x 80mm. Load capacity 210kg.



	NAME	DATE	 BIL Group Ltd, Porte Marsh Road, Calne Wiltshire, SN11 9BW, United Kingdom Tel +44 (0)1249 822 222 Fax: +44 (0)1249 822 300 www.bilgroup.co.uk	
DRAWN	Matt	29/03/18	TITLE	
APPROVED BY	Tim W	29/03/18	BZJF100CRBJ	
SCALE	1:3	29/03/18	SIZE	DWG NO.
WEIGHT	2.416kg	29/03/18	A4	BILCW03BZJF100CRBJ_01
UNLESS OTHERWISE SPECIFIED DIMENSIONS ARE IN MILLIMETRES			REV	1
Unspecified Tolerances Machining ± 0.25mm Fabrication ± 1mm			FILE NAME	BILCW03BZJF100CRBJ_01.PDF SHEET 1 OF 1