

DRAWING DISCLAIMER
 COPYRIGHT OF THIS DRAWING IS RESERVED BY BIL GROUP LTD. IT IS ISSUED ON CONDITION THAT IT IS NOT REPRODUCED, COPIED, OR DISCLOSED TO A THIRD PARTY EITHER WHOLLY OR IN PART WITHOUT THE CONSENT IN WRITING OF BIL GROUP LTD.

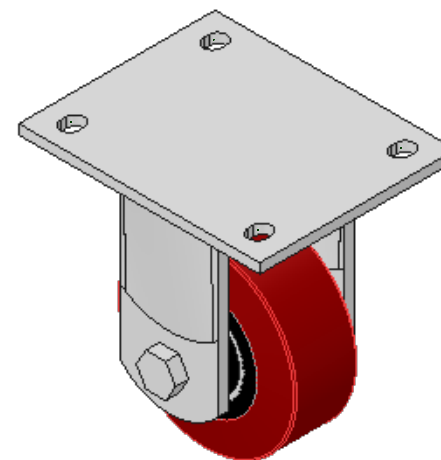

Description:
 BZJF100PTBJ

Fabricated fixed castor with a top plate fixing fitted with a polyurethane tyred cast iron centred wheel with ball bearings. Wheel diameter 100mm, tread width 40mm, overall height 143mm, top plate 135mm x 110mm, hole centres 105mm x 80mm. Load capacity 310kg.

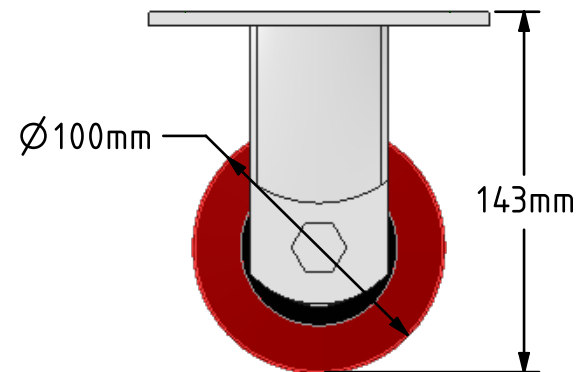
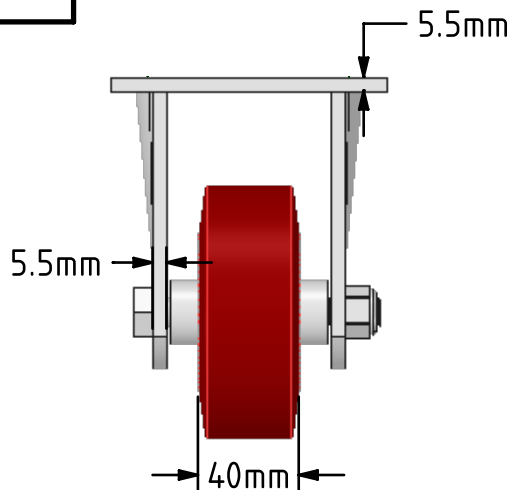
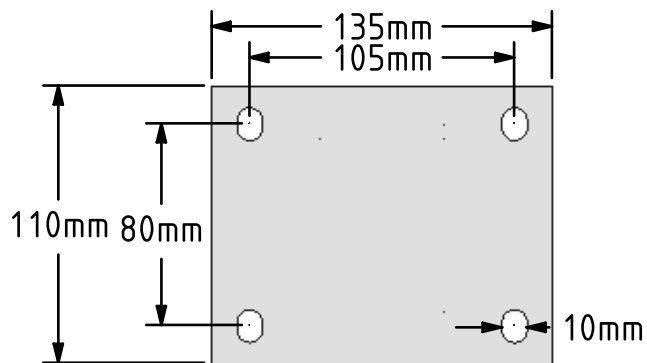

	NAME	DATE
DRAWN	Matt	09/04/18
APPROVED BY	Chris	09/04/18
SCALE	1:3	09/04/18
WEIGHT	2.142kg	09/04/18

UNLESS OTHERWISE SPECIFIED DIMENSIONS ARE IN MILLIMETRES

Unspecified Tolerances
 Machining ± 0.25mm
 Fabrication ± 1mm



BIL Group Ltd, Porte Marsh Road, Calne
 Wiltshire, SN11 9BW, United Kingdom
 Tel +44 (0)1249 822 222 Fax: +44 (0)1249 822 300
 www.bilgroup.co.uk

TITLE

BZJF100PTBJ

SIZE DWG NO.
 A4 BILCW03BZJF100PTBJ_01

REV
 1

FILE NAME BILCW03BZJF100PTBJ_01.PDF SHEET 1 OF 1