

DRAWING DISCLAIMER  
 COPYRIGHT OF THIS DRAWING IS RESERVED BY BIL GROUP LTD. IT IS ISSUED ON CONDITION THAT IT IS NOT REPRODUCED, COPIED, OR DISCLOSED TO A THIRD PARTY EITHER WHOLLY OR IN PART WITHOUT THE CONSENT IN WRITING OF BIL GROUP LTD.

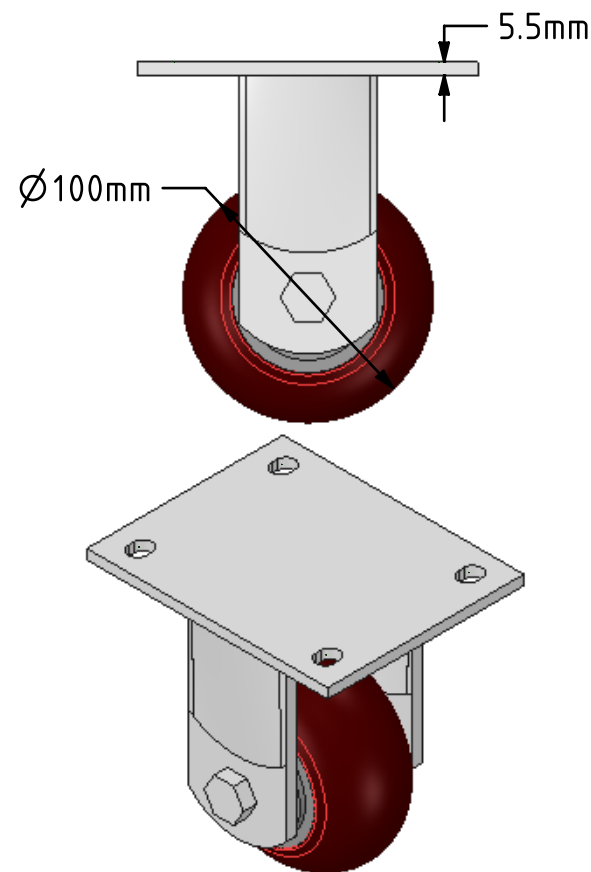

Description:  
 BZJF100RPTABJ

Fabricated fixed castor with a top plate fixing fitted with a ergonomic brown polyurethane tyred on aluminium centred wheel with ball bearings. Wheel diameter 100mm, tread width 50mm, overall height 143mm, top plate 138mm x 110mm, Hole centres 105mm x 80mm/75mm. Load capacity 350kg.

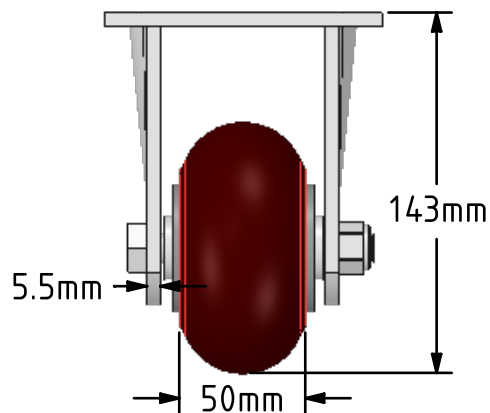
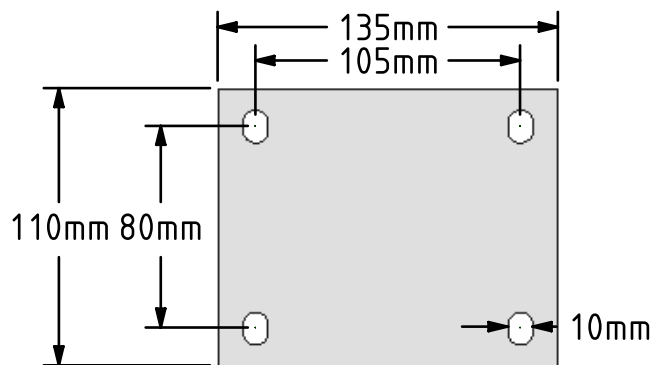

	NAME	DATE
DRAWN	Matt	06/04/18
APPROVED BY	Kevin	06/04/18
SCALE	1:3	06/04/18
WEIGHT	1.954kg	06/04/18

UNLESS OTHERWISE SPECIFIED DIMENSIONS ARE IN MILLIMETRES

Unspecified Tolerances  
 Machining ± 0.25mm  
 Fabrication ± 1mm



BIL Group Ltd, Porte Marsh Road, Calne  
 Wiltshire, SN11 9BW, United Kingdom  
 Tel +44 (0)1249 822 222 Fax: +44 (0)1249 822 300  
 www.bilgroup.co.uk

TITLE

BZJF100RPTABJ

SIZE DWG NO.

A4

BILCW03BZJF100RPTABJ\_01

REV

1

FILE NAME

BILCW03BZJF100RPTABJ\_01.PDF

SHEET 1 OF 1