

DRAWING DISCLAIMER

COPYRIGHT OF THIS DRAWING IS RESERVED BY BIL GROUP LTD. IT IS ISSUED ON CONDITION THAT IT IS NOT REPRODUCED, COPIED, OR DISCLOSED TO A THIRD PARTY EITHER WHOLLY OR IN PART WITHOUT THE CONSENT IN WRITING OF BIL GROUP LTD.

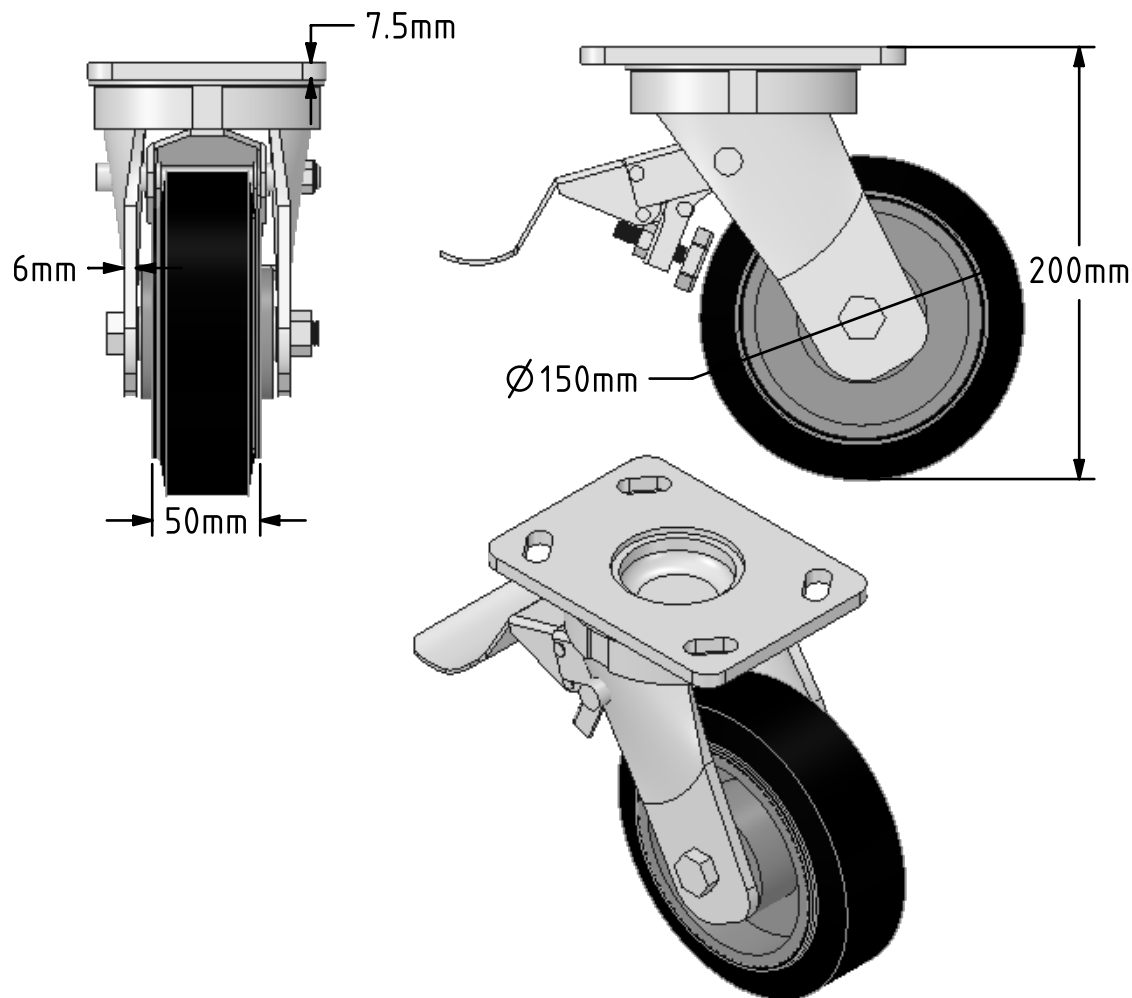
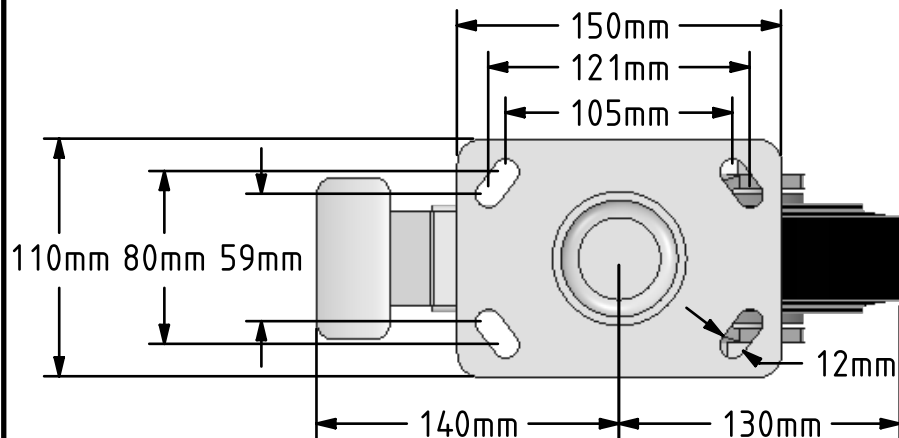

Description:
BZK150CUBJSWB

Fabricated swivel castor with top plate fixing fitted with a black rubber tyre on a cast iron centred wheel with a ball bearing and total lock brake. Wheel diameter 150mm, tread width 50mm, overall height 200mm, top plate 150mm x 110mm, hole centres 105mm x 80mm or 121mm x 59mm. Load capacity 400kg.
 - At 6 kph speed, the load of each wheel is advised to be 80% of the load at 4kph.
 - At 10 kph speed, the load of each wheel is advised to be 55% of the load at 4 kph.
 - At 16 kph speed, the load of each wheel is advised to be 45% of the load at 4kph.
 - At 20 kph speed, the load of each wheel is advised to be 35% of the load at 4 kph.
 - No data for elastic rubber wheel over 20 kph.



	NAME	DATE
DRAWN	Matt	11/07/18
APPROVED BY	Tim W	11/07/18
SCALE	2:7	11/07/18
WEIGHT	5.803kg	11/07/18

UNLESS OTHERWISE SPECIFIED DIMENSIONS ARE IN MILLIMETRES

Unspecified Tolerances
 Machining ± 0.25mm
 Fabrication ± 1mm



BIL Group Ltd, Porte Marsh Road, Calne
 Wiltshire, SN11 9BW, United Kingdom
 Tel +44 (0)1249 822 222 Fax: +44 (0)1249 822 300
 www.bilgroup.co.uk

TITLE

BZK150CUBJSWB

SIZE DWG NO.

A4

BILCW03BZK150CUBJSWB_01

REV

1

FILE NAME BILCW03BZK150CUBJSWB_01.PDF

SHEET 1 OF 1