

DRAWING DISCLAIMER
 COPYRIGHT OF THIS DRAWING IS RESERVED BY BIL GROUP LTD. IT IS ISSUED ON CONDITION THAT IT IS NOT REPRODUCED, COPIED, OR DISCLOSED TO A THIRD PARTY EITHER WHOLLY OR IN PART WITHOUT THE CONSENT IN WRITING OF BIL GROUP LTD.

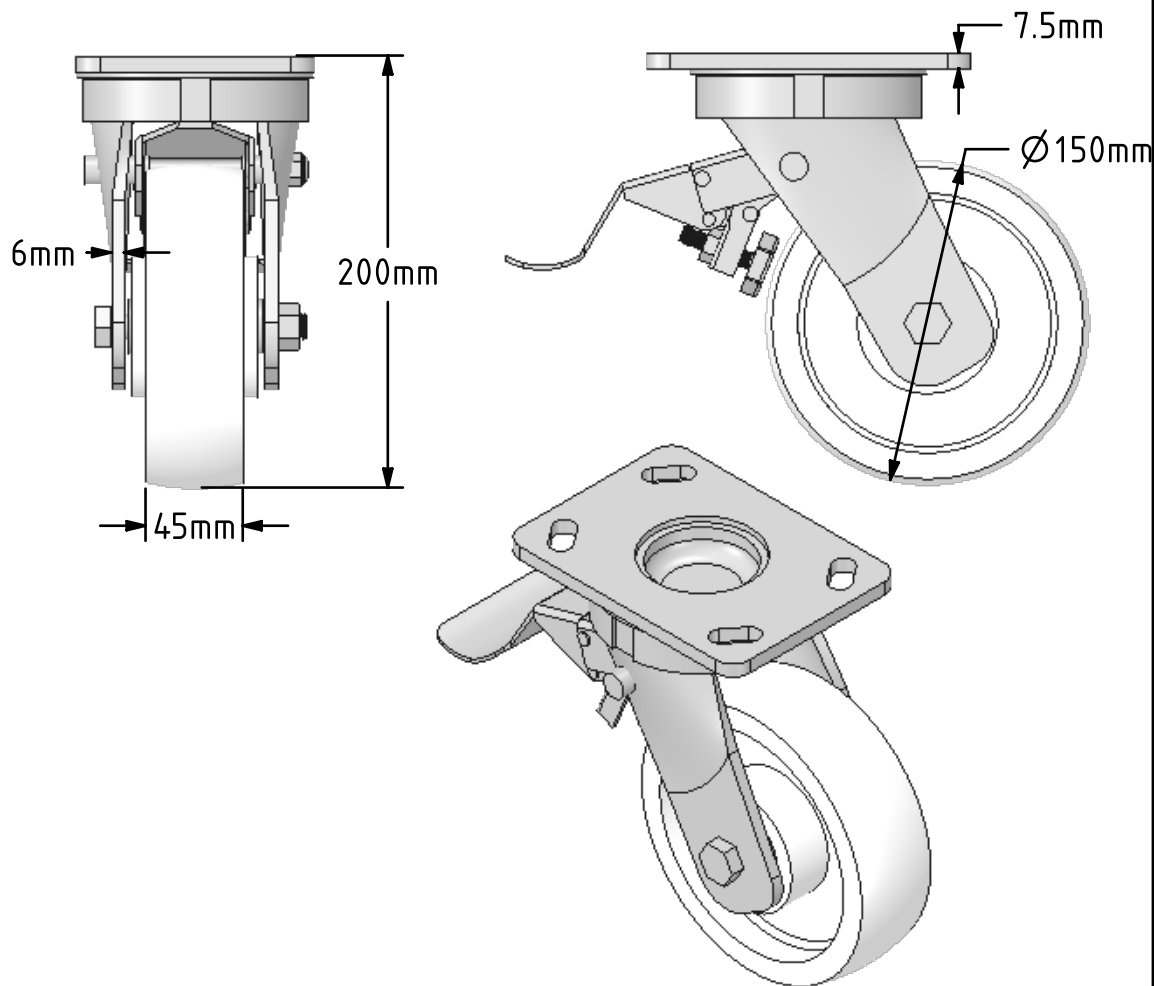

Description:
 BZK150NYBJSWB

Fabricated swivel castor with a top plate fixing fitted with a white nylon wheel with ball bearings and total lock brake. Wheel diameter 150mm, tread width 45mm, overall height 200mm, top plate 150mm x 110mm, hole centres 105mm x 80mm or 121mm x 59mm. Load capacity 1000kg.

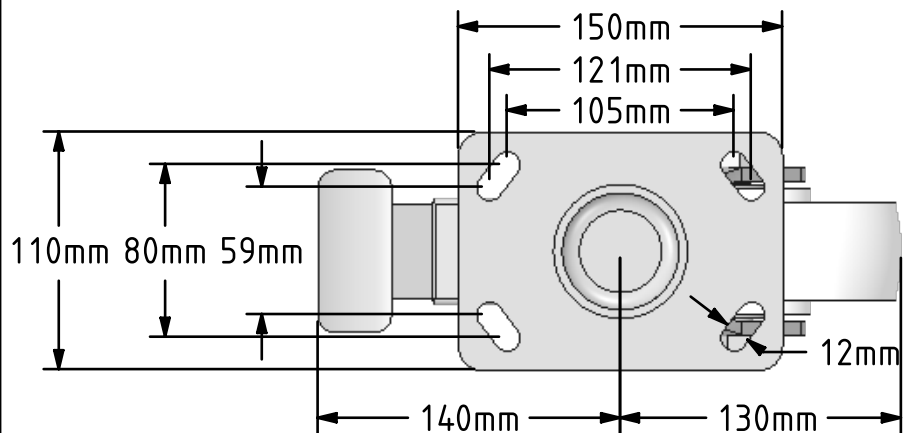

	NAME	DATE
DRAWN	Matt	11/07/18
APPROVED BY	Chris	11/07/18
SCALE	2:7	11/07/18
WEIGHT	4.339kg	11/07/18

UNLESS OTHERWISE SPECIFIED DIMENSIONS ARE IN MILLIMETRES

Unspecified Tolerances
 Machining ± 0.25mm
 Fabrication ± 1mm



BIL Group Ltd, Porte Marsh Road, Calne
 Wiltshire, SN11 9BW, United Kingdom
 Tel +44 (0)1249 822 222 Fax: +44 (0)1249 822 300
 www.bilgroup.co.uk

TITLE

BZK150NYBJSWB

SIZE	DWG NO.	REV
A4	BILCW03BZK150NYBJSWB_01	1

FILE NAME BILCW03BZK150NYBJSWB_01.PDF SHEET 1 OF 1