

DRAWING DISCLAIMER  
 COPYRIGHT OF THIS DRAWING IS RESERVED BY BIL GROUP LTD. IT IS ISSUED ON CONDITION THAT IT IS NOT REPRODUCED, COPIED, OR DISCLOSED TO A THIRD PARTY EITHER WHOLLY OR IN PART WITHOUT THE CONSENT IN WRITING OF BIL GROUP LTD.

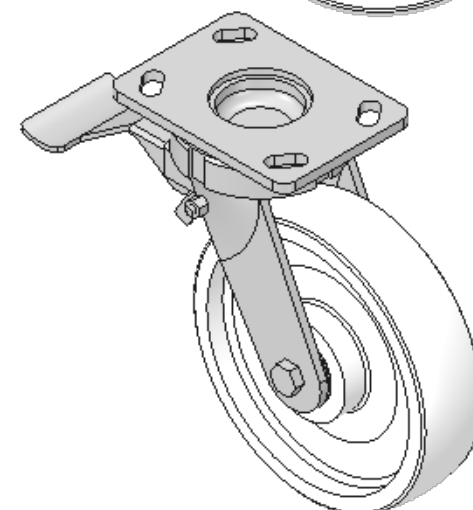

Description:  
 BZK200NYBJSWB

Fabricated swivel castor with a top plate fixing fitted with a nylon wheel with ball bearings and total lock brake. Wheel diameter 200mm, tread width 50mm, overall height 250mm, top plate 150mm x 110mm, hole centres 105mm x 80mm or 121mm x 59mm. Load capacity 1000kg.

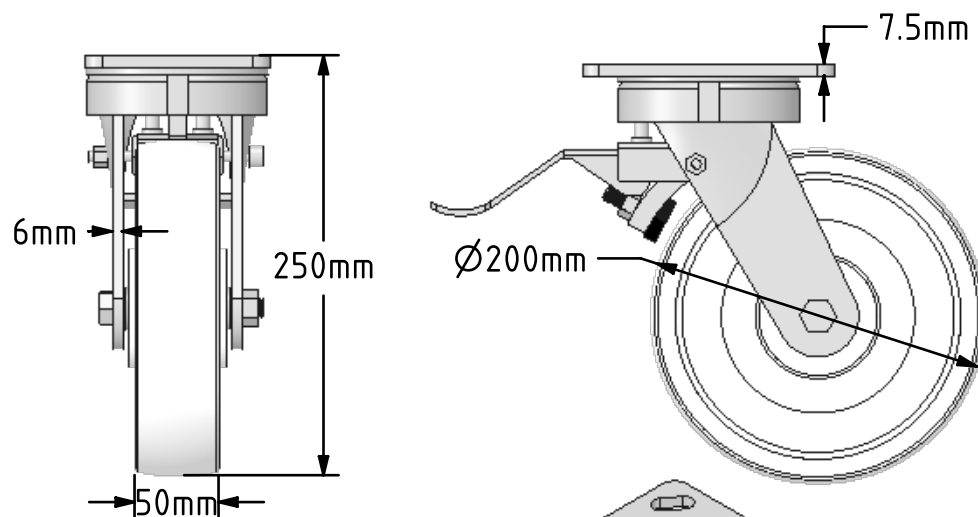
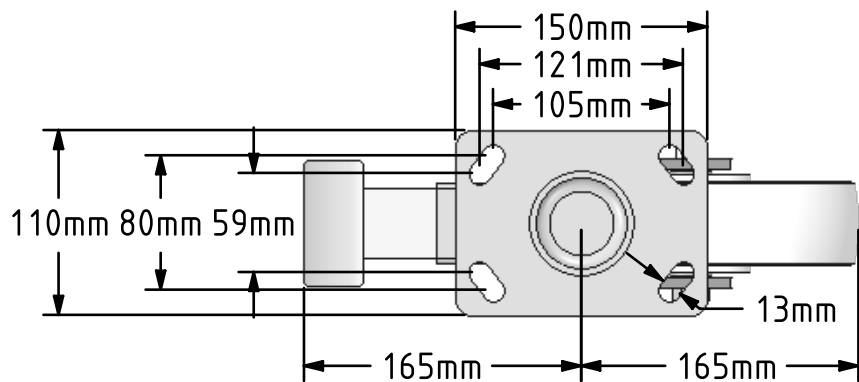

	NAME	DATE
DRAWN	Matt	01/02/18
APPROVED BY	Tim W	01/02/18
SCALE	2:9	01/02/18
WEIGHT	4.807kg	01/02/18

**BIL**  
 BIL Group Ltd, Porte Marsh Road, Calne  
 Wiltshire, SN11 9BW, United Kingdom  
 Tel +44 (0)1249 822 222 Fax: +44 (0)1249 822 300  
 www.bilgroup.co.uk

TITLE  
**BZK200NYBJSWB**

UNLESS OTHERWISE SPECIFIED DIMENSIONS ARE IN MILLIMETRES  
 Unspecified Tolerances  
 Machining ± 0.25mm  
 Fabrication ± 1mm

SIZE	DWG NO.	REV
A4	BILCW03BZK200NYBJSWB_01	1
FILE NAME BILCW03BZK200NYBJSWB_01.PDF		SHEET 1 OF 1