

DRAWING DISCLAIMER
 COPYRIGHT OF THIS DRAWING IS RESERVED BY BIL GROUP LTD. IT IS ISSUED ON CONDITION THAT IT IS NOT REPRODUCED, COPIED, OR DISCLOSED TO A THIRD PARTY EITHER WHOLLY OR IN PART WITHOUT THE CONSENT IN WRITING OF BIL GROUP LTD.

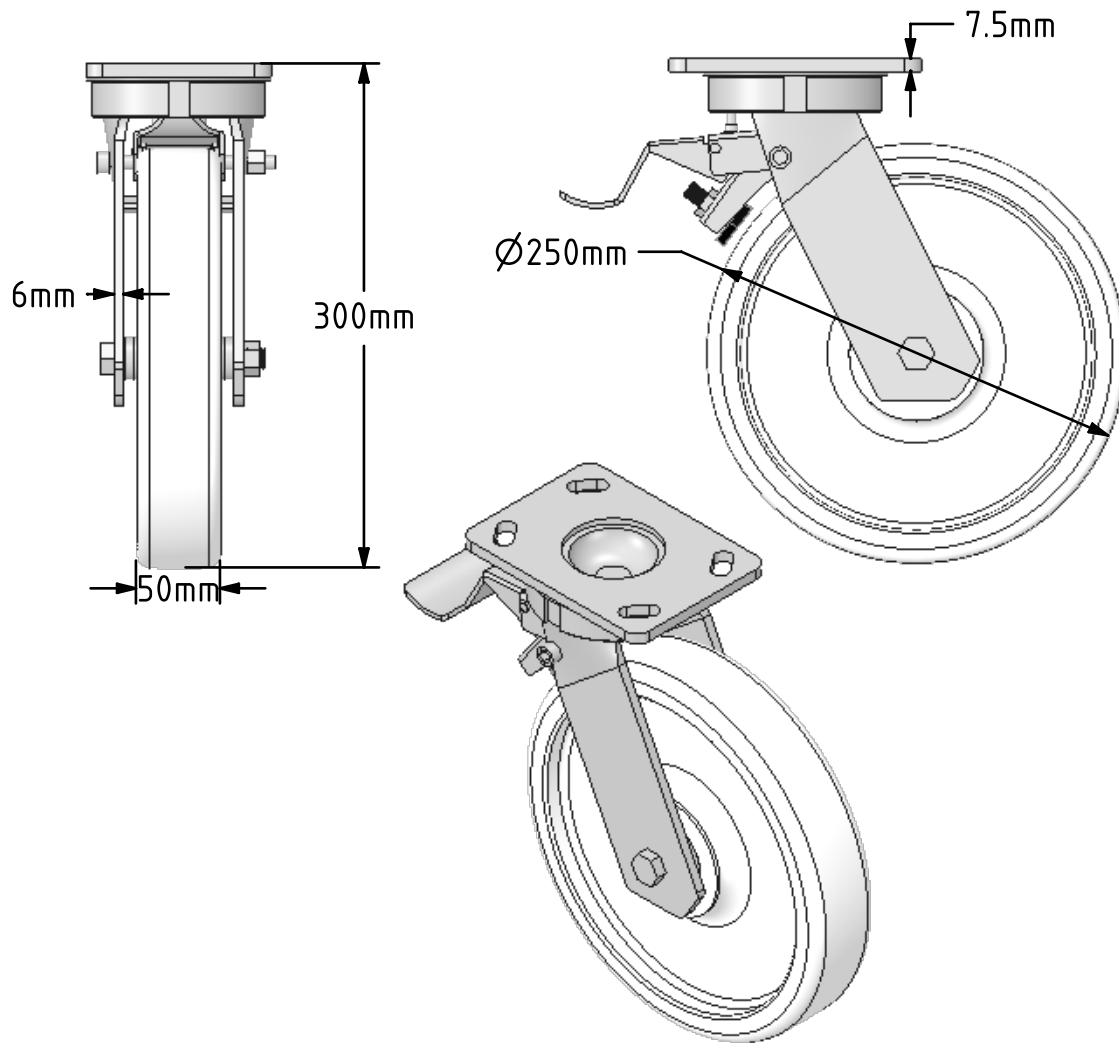

Description:
 BZK250NYBJSWB

Fabricated swivel castor with a top plate fixing fitted with a white nylon wheel with ball bearings and total lock brake. Wheel diameter 250mm, tread width 50mm, overall height 300mm, top plate 150mm x 110mm, hole centres 105mm x 80mm or 121mm x 59mm. Load capacity 1200kg.

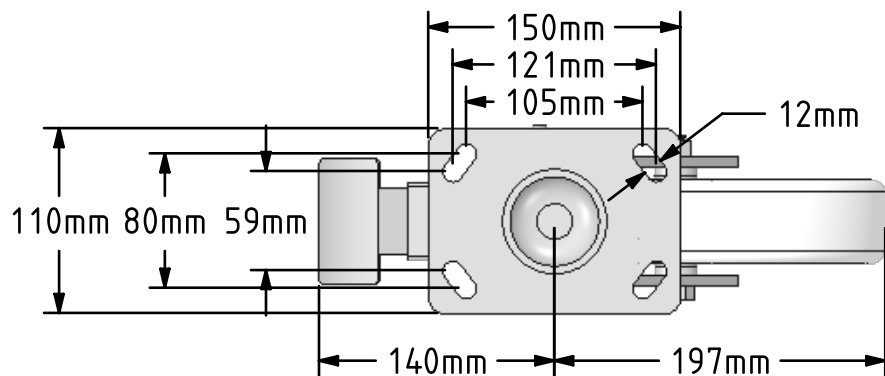

	NAME	DATE
DRAWN	Matt	10/07/18
APPROVED BY	Tim W	10/07/18
SCALE	2:9	10/07/18
WEIGHT	5.747kg	10/07/18

BIL BIL Group Ltd, Porte Marsh Road, Calne
 Wiltshire, SN11 9BW, United Kingdom
 Tel +44 (0)1249 822 222 Fax: +44 (0)1249 822 300
 www.bilgroup.co.uk

TITLE
BZK250NYBJSWB

UNLESS OTHERWISE SPECIFIED DIMENSIONS ARE IN MILLIMETRES
 Unspecified Tolerances
 Machining ± 0.25mm
 Fabrication ± 1mm

SIZE	DWG NO.	REV
A4	BILCW03BZK250NYBJSWB_01	1
FILE NAME	BILCW03BZK250NYBJSWB_01.PDF SHEET 1 OF 1	