

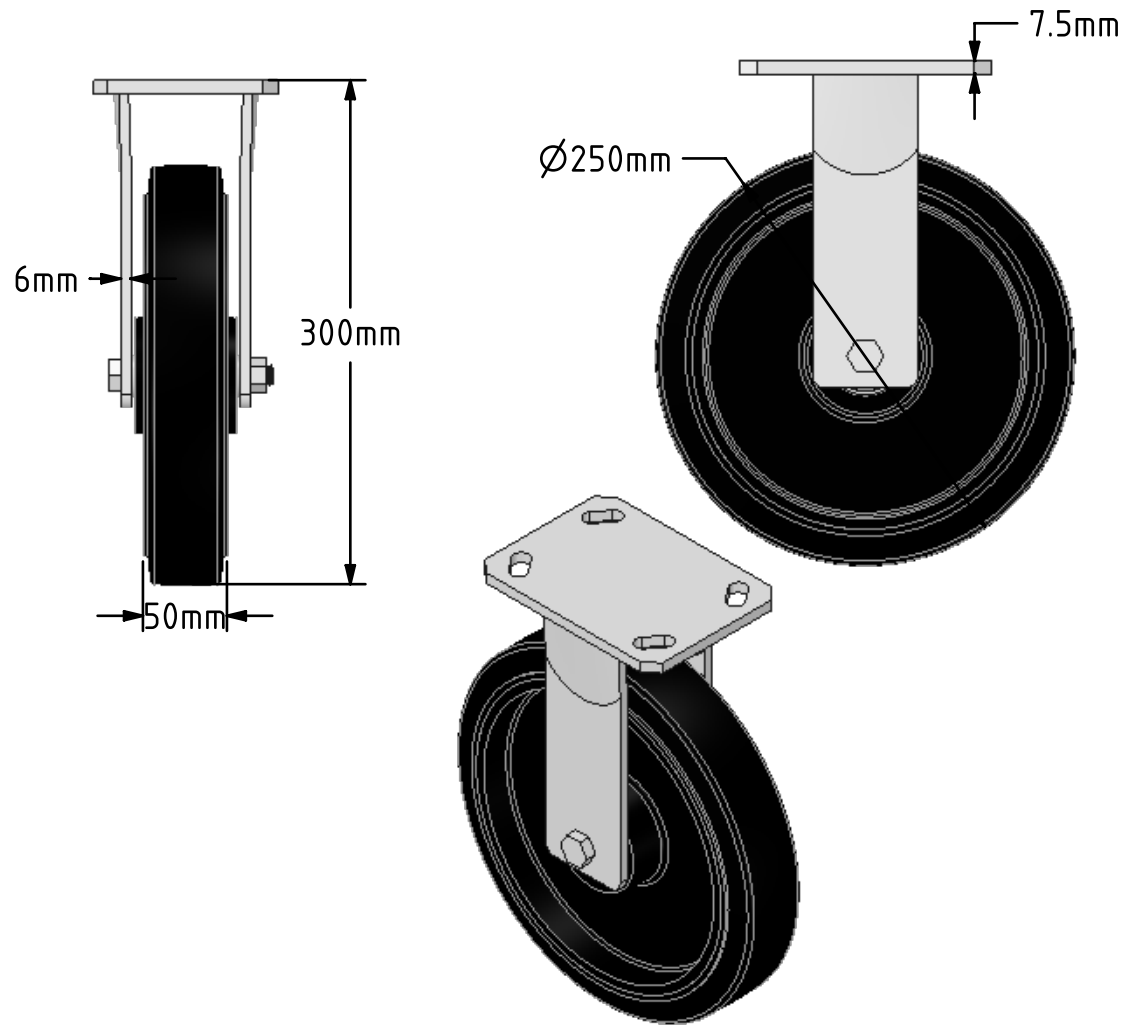

**DRAWING DISCLAIMER**  
 COPYRIGHT OF THIS DRAWING IS RESERVED BY BIL GROUP LTD. IT IS ISSUED ON CONDITION THAT IT IS NOT REPRODUCED, COPIED, OR DISCLOSED TO A THIRD PARTY EITHER WHOLLY OR IN PART WITHOUT THE CONSENT IN WRITING OF BIL GROUP LTD.

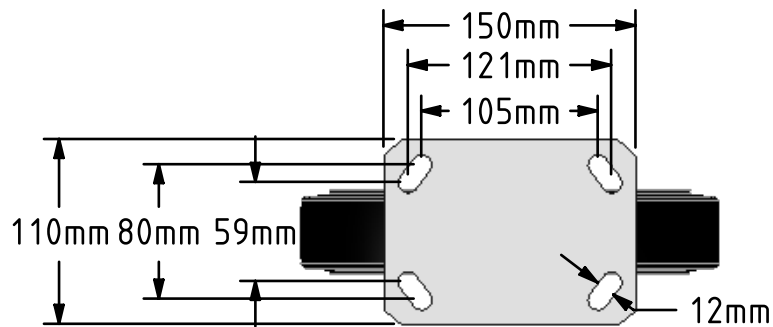

**Description:**  
 BZKF250CRBJ  
 Fabricated fixed castor with a top plate fixing fitted with a black elastic rubber tyre on cast iron centred wheel with ball bearings. Wheel diameter 250mm, tread width 50mm, overall height 300mm, top plate 150mm x 110mm, hole centres 105mm x 80mm or 121mm x 59mm. Load capacity 500kg.



	NAME	DATE	 BIL Group Ltd, Porte Marsh Road, Calne Wiltshire, SN11 9BW, United Kingdom Tel +44 (0)1249 822 222 Fax: +44 (0)1249 822 300 www.bilgroup.co.uk
DRAWN	Matt	05/07/18	
APPROVED BY	Chris	05/07/18	
SCALE	2:9	05/07/18	
WEIGHT	7.829kg	05/07/18	
UNLESS OTHERWISE SPECIFIED DIMENSIONS ARE IN MILLIMETRES Unspecified Tolerances Machining ± 0.25mm Fabrication ± 1mm			TITLE <b>BZKF250CRBJ</b>
SIZE	DWG NO.		REV
A4	BILCW03BZKF250CRBJ_01		1
FILE NAME	BILCW03BZKF250CRBJ_01.PDF		SHEET 1 OF 1