

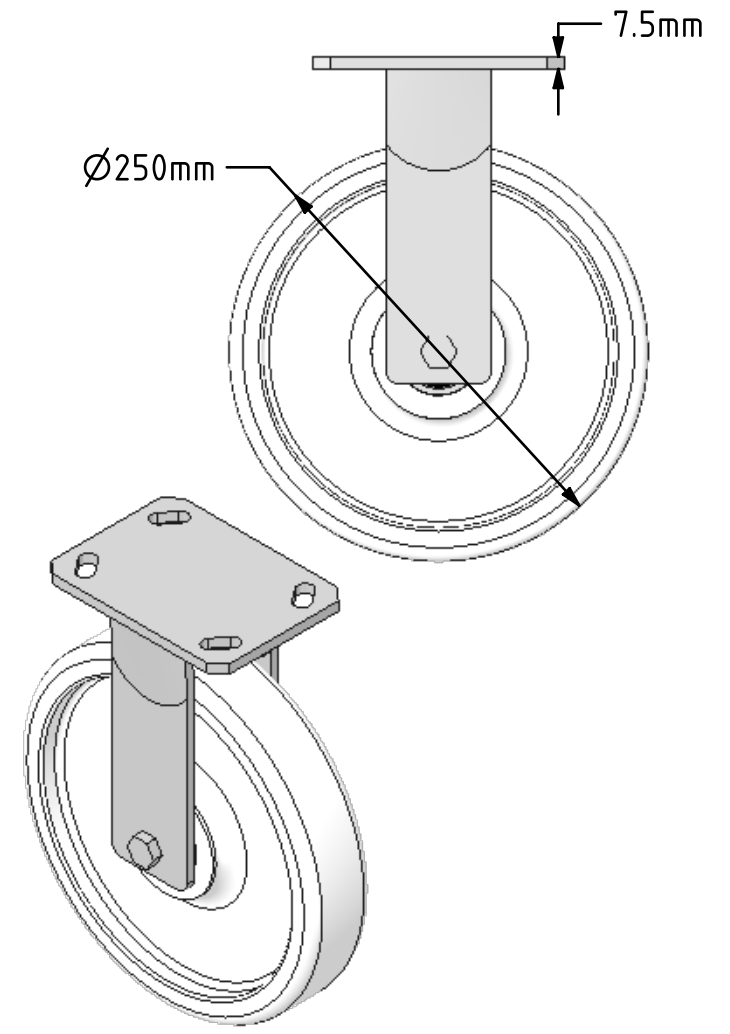

DRAWING DISCLAIMER
 COPYRIGHT OF THIS DRAWING IS RESERVED BY BIL GROUP LTD. IT IS ISSUED ON CONDITION THAT IT IS NOT REPRODUCED, COPIED, OR DISCLOSED TO A THIRD PARTY EITHER WHOLLY OR IN PART WITHOUT THE CONSENT IN WRITING OF BIL GROUP LTD.

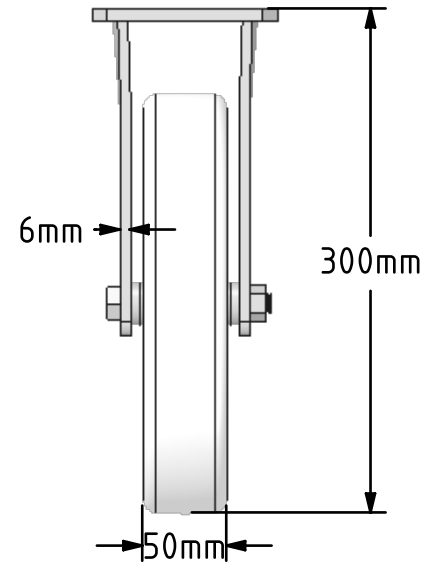

Description:
 BZKF250NYBJ
 Fabricated fixed castor with a top plate fixing fitted with a white nylon wheel with ball journal bearings. Wheel diameter 250mm, tread width 50mm, overall height 300mm, top plate 150mm x 110mm, hole centres 105mm x 80mm or 121mm x 59mm. Load capacity 1200kg.

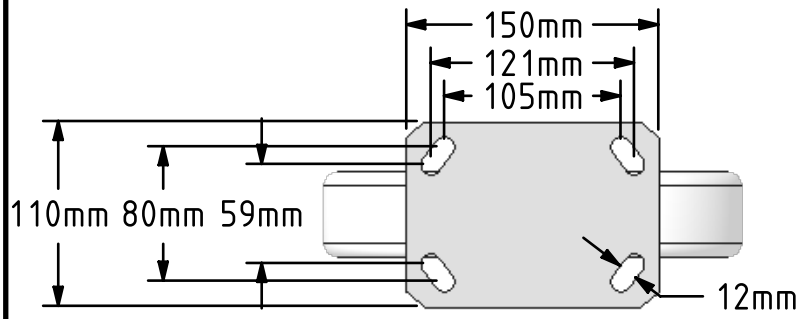

	NAME	DATE	 BIL Group Ltd, Porte Marsh Road, Calne Wiltshire, SN11 9BW, United Kingdom Tel +44 (0)1249 822 222 Fax: +44 (0)1249 822 300 www.bilgroup.co.uk	
DRAWN	Matt	11/07/18	TITLE	
APPROVED BY	Tim W	11/07/18	BZKF250NYBJ	
SCALE	2:9	11/07/18	SIZE	DWG NO.
WEIGHT	3.794kg	11/07/18	A4	BILW03BZKF250NYBJ_01
UNLESS OTHERWISE SPECIFIED DIMENSIONS ARE IN MILLIMETRES			REV	1
Unspecified Tolerances Machining ± 0.25mm Fabrication ± 1mm			FILE NAME	BILW03BZKF250NYBJ_01.PDF
			SHEET	1 OF 1