

**DRAWING DISCLAIMER**  
 COPYRIGHT OF THIS DRAWING IS RESERVED BY BIL GROUP LTD. IT IS ISSUED ON CONDITION THAT IT IS NOT REPRODUCED, COPIED, OR DISCLOSED TO A THIRD PARTY EITHER WHOLLY OR IN PART WITHOUT THE CONSENT IN WRITING OF BIL GROUP LTD.

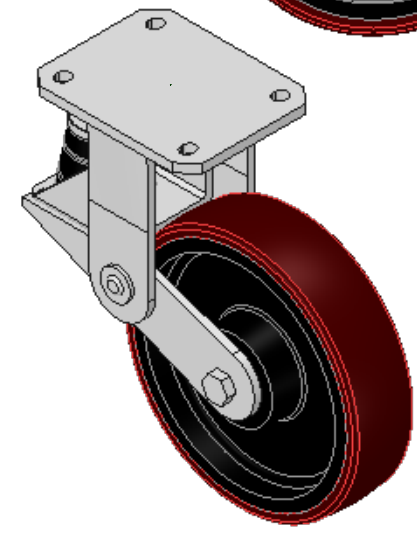

**Description:**  
 BZKFL200PTBJSR200  
 Fabricated fixed castor with top plate fixing fitted with a 200mm x 50mm brown polyurethane tyred cast iron centred wheel with ball bearings overall height 237mm/257mm, plate size 138mm x 110mm, hole centres 105mm x 80mm. Load capacity 200kg black rubber spring,max speed 4kph

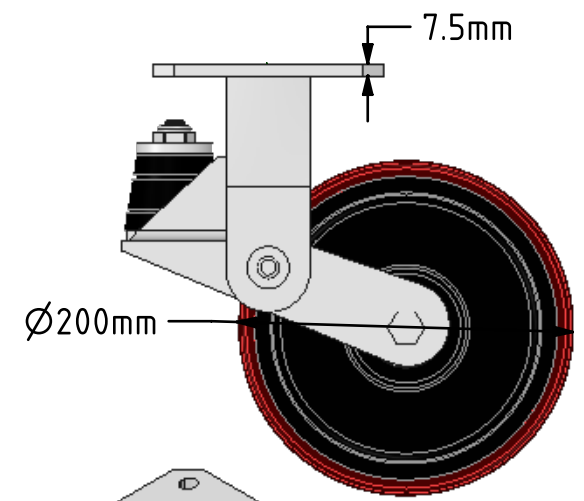
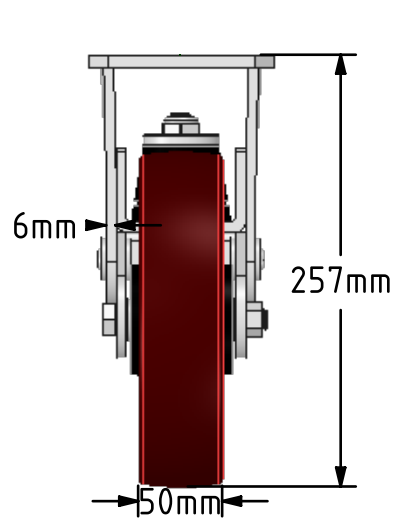
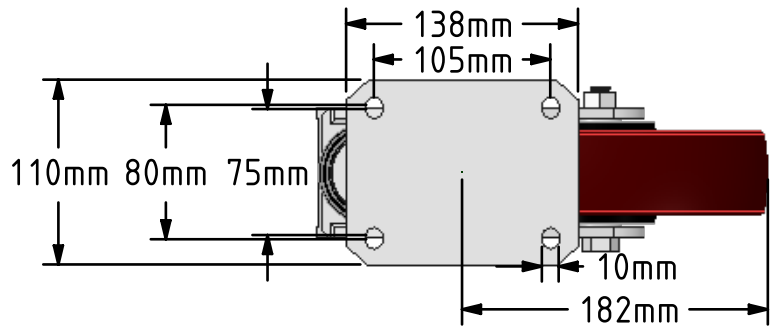

	NAME	DATE
DRAWN	Matt	09/05/18
APPROVED BY	Tim W	09/05/18
SCALE	2:9	09/05/18
WEIGHT	6.759kg	09/05/18

UNLESS OTHERWISE SPECIFIED DIMENSIONS ARE IN MILLIMETRES  
 Unspecified Tolerances  
 Machining ± 0.25mm  
 Fabrication ± 1mm

**BIL**  
 BIL Group Ltd, Porte Marsh Road, Calne  
 Wiltshire, SN11 9BW, United Kingdom  
 Tel +44 (0)1249 822 222 Fax: +44 (0)1249 822 300  
 www.bilgroup.co.uk

TITLE		
BZKFL200PTBJSR200		
SIZE	DWG NO.	REV
A4	BILCW03BZKFL200PTBJSR200_01	1
FILE NAME BILCW03BZKFL200PTBJSR200_01.PDF SHEET 1 OF 1		