

DRAWING DISCLAIMER
 COPYRIGHT OF THIS DRAWING IS RESERVED BY BIL GROUP LTD. IT IS ISSUED ON CONDITION THAT IT IS NOT REPRODUCED, COPIED, OR DISCLOSED TO A THIRD PARTY EITHER WHOLLY OR IN PART WITHOUT THE CONSENT IN WRITING OF BIL GROUP LTD.

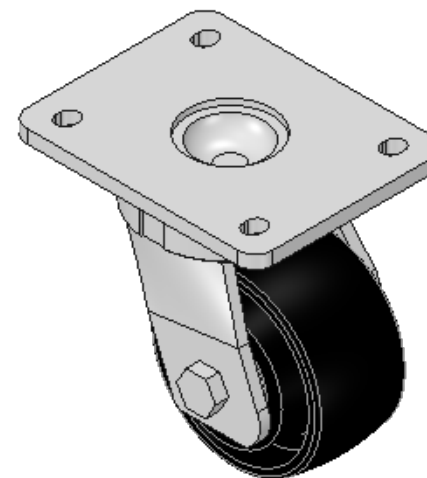

Description:
 BZKL100CIBJ

Fabricated swivel castor with a top plate fixing fitted with a cast iron wheel with ball bearings. Wheel diameter 100mm, tread width 50mm, overall height 140mm, top plate 138mm x 110mm, hole centres 105mm x 80/75mm. Load capacity 400kg

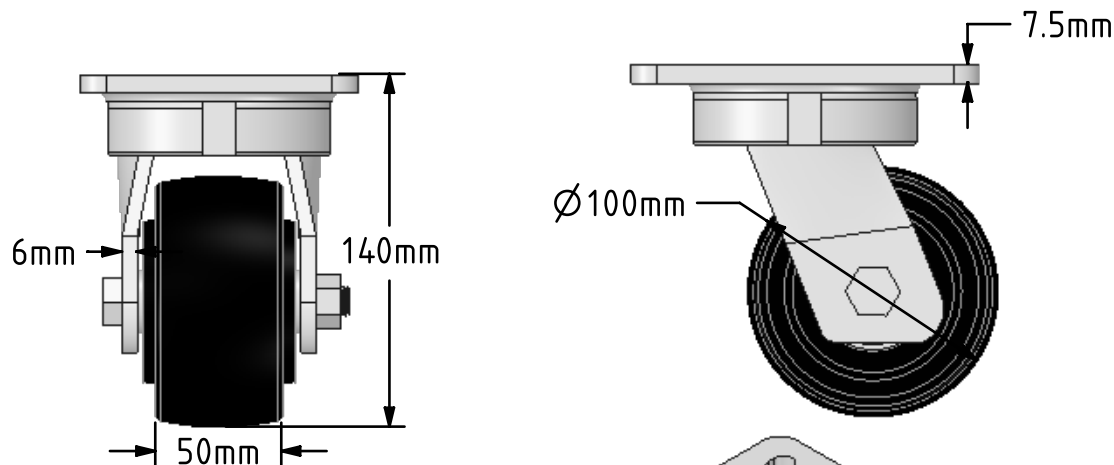
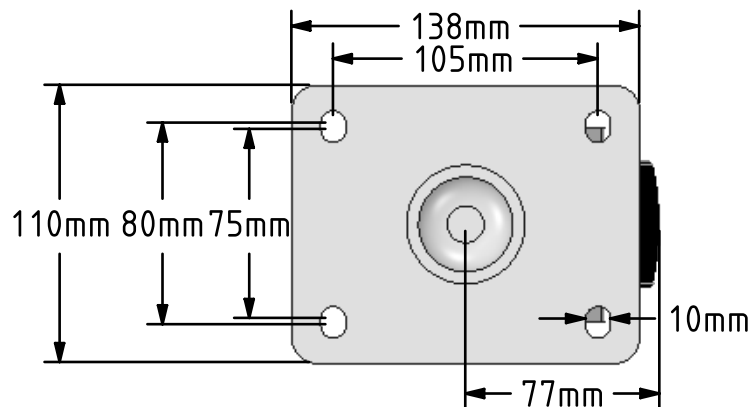

	NAME	DATE
DRAWN	Matt	26/04/18
APPROVED BY	Tim W	26/04/18
SCALE	1:3	26/04/18
WEIGHT	4.297kg	26/04/18

 BIL Group Ltd, Porte Marsh Road, Calne Wiltshire, SN11 9BW, United Kingdom
 Tel +44 (0)1249 822 222 Fax: +44 (0)1249 822 300
 www.bilgroup.co.uk

TITLE
BZKL100CIBJ

UNLESS OTHERWISE SPECIFIED DIMENSIONS ARE IN MILLIMETRES
 Unspecified Tolerances
 Machining ± 0.25mm
 Fabrication ± 1mm

SIZE	DWG NO.	REV
A4	BILCW03BZKL100CIBJ_01	1
FILE NAME	BILCW03BZKL100CIBJ_01.PDF SHEET 1 OF 1	