

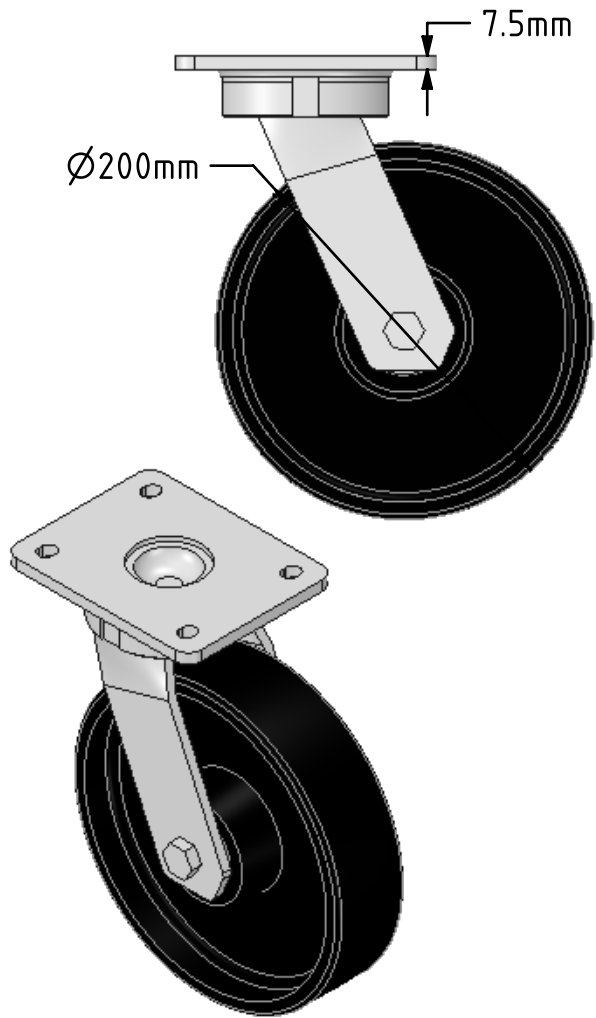

DRAWING DISCLAIMER
 COPYRIGHT OF THIS DRAWING IS RESERVED BY BIL GROUP LTD. IT IS ISSUED ON CONDITION THAT IT IS NOT REPRODUCED, COPIED, OR DISCLOSED TO A THIRD PARTY EITHER WHOLLY OR IN PART WITHOUT THE CONSENT IN WRITING OF BIL GROUP LTD.

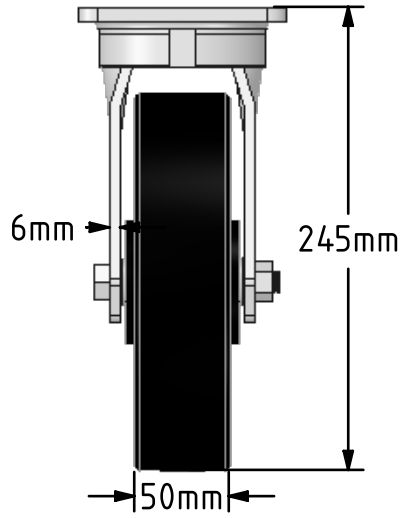

Description:
 BZKL200CIBJ
 Fabricated swivel castor with a top plate fixing fitted with a cast iron wheel with ball bearing. Wheel diameter 200mm, tread width 50mm, overall height 245mm, top plate 138mm x 110mm, hole centres 105mm x 80mm/75mm.

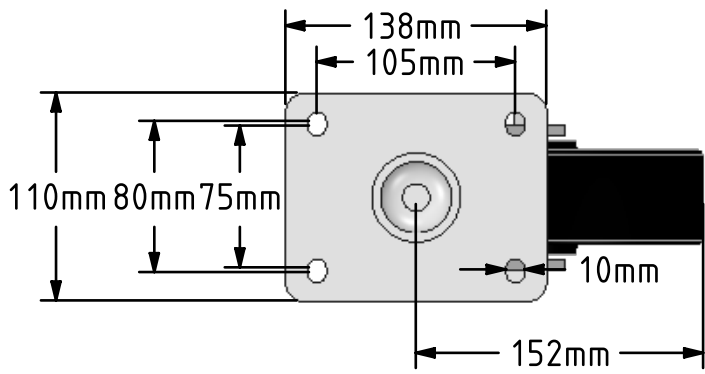

	NAME	DATE	 BIL Group Ltd, Porte Marsh Road, Calne Wiltshire, SN11 9BW, United Kingdom Tel +44 (0)1249 822 222 Fax: +44 (0)1249 822 300 www.bilgroup.co.uk
DRAWN	Matt	27/04/18	
APPROVED BY	Chris	27/04/18	
SCALE	1:4	27/04/18	
WEIGHT	7.291kg	27/04/18	
UNLESS OTHERWISE SPECIFIED DIMENSIONS ARE IN MILLIMETRES Unspecified Tolerances Machining ± 0.25mm Fabrication ± 1mm			TITLE BZKL200CIBJ
SIZE	DWG NO.		REV
A4	BILCW03BZKL200CIBJ_01		1
FILE NAME	BILCW03BZKL200CIBJ_01.PDF		SHEET 1 OF 1