

DRAWING DISCLAIMER
 COPYRIGHT OF THIS DRAWING IS RESERVED BY BIL GROUP LTD. IT IS ISSUED ON CONDITION THAT IT IS NOT REPRODUCED, COPIED, OR DISCLOSED TO A THIRD PARTY EITHER WHOLLY OR IN PART WITHOUT THE CONSENT IN WRITING OF BIL GROUP LTD.

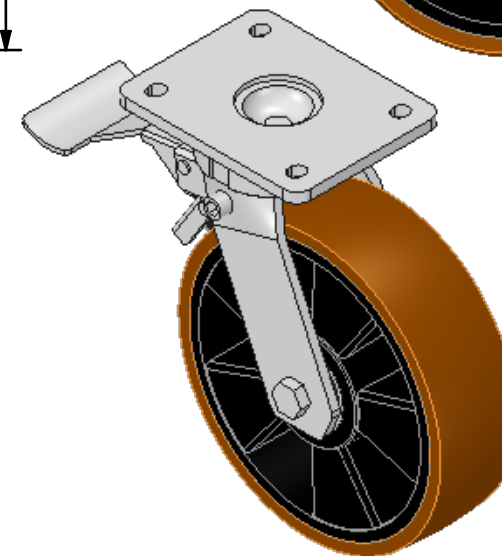

Description:
 BZKL200XPNBJSWB

Fabricated swivel castor with a top plate fixing fitted with a brown polyurethane tyred wheel on a black nylon centred wheel with ball bearings and a total lock brake. Wheel diameter 200mm, tread width 57mm, overall height 245mm, top plate 138mm x 110mm, hole centres 105mm x 80/75mm. Load capacity 800kg

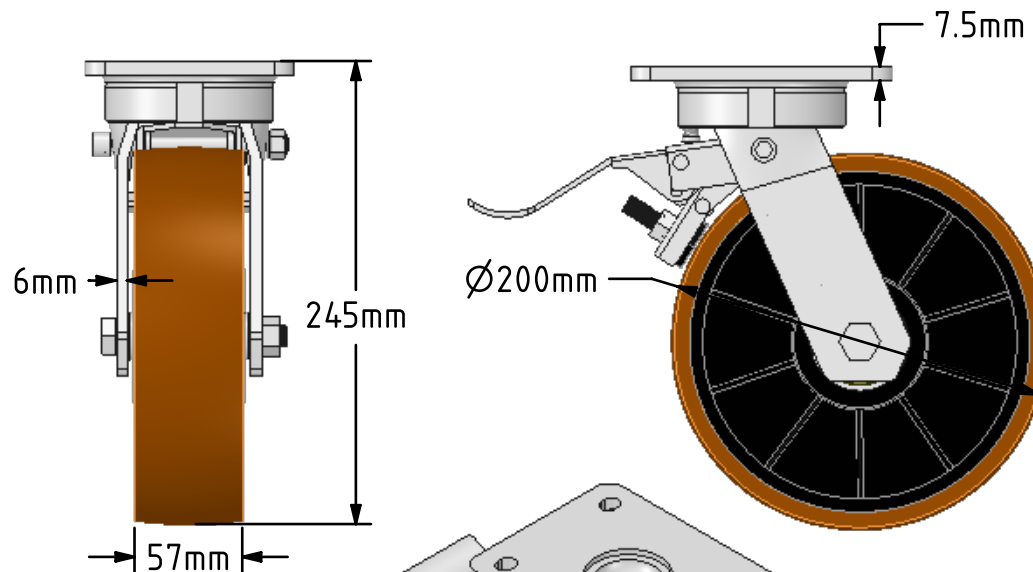
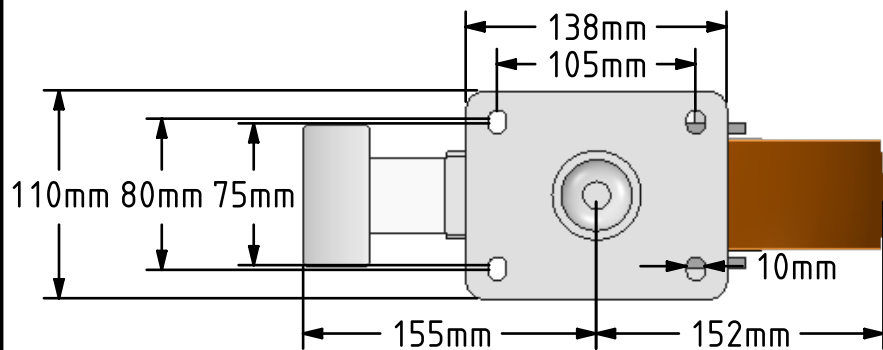

	NAME	DATE
DRAWN	Matt	27/04/18
APPROVED BY	Chris	27/04/18
SCALE	1:4	27/04/18
WEIGHT	4.562kg	27/04/18

UNLESS OTHERWISE SPECIFIED DIMENSIONS ARE IN MILLIMETRES

Unspecified Tolerances
 Machining ± 0.25mm
 Fabrication ± 1mm

	BIL Group Ltd, Porte Marsh Road, Calne Wiltshire, SN11 9BW, United Kingdom Tel +44 (0)1249 822 222 Fax: +44 (0)1249 822 300 www.bilgroup.co.uk	
	TITLE BZKL200XPNBJSWB	

SIZE	DWG NO.	REV
A4	BILCW03BZKL200XPNBJSWB_01	1

FILE NAME BILCW03BZKL200XPNBJSWB_01.PDF SHEET 1 OF 1