

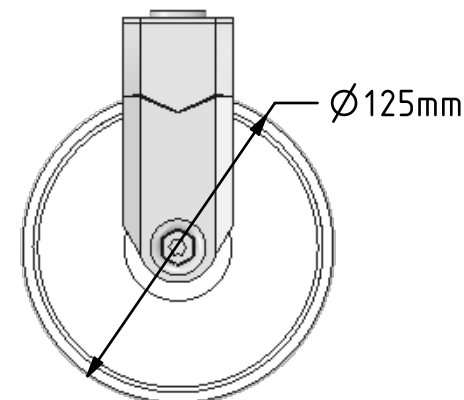

DRAWING DISCLAIMER
 COPYRIGHT OF THIS DRAWING IS RESERVED BY BIL GROUP LTD. IT IS ISSUED ON CONDITION THAT IT IS NOT REPRODUCED, COPIED, OR DISCLOSED TO A THIRD PARTY EITHER WHOLLY OR IN PART WITHOUT THE CONSENT IN WRITING OF BIL GROUP LTD.

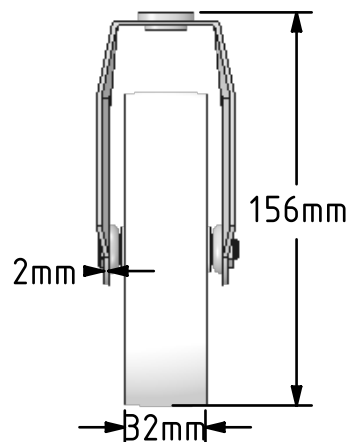
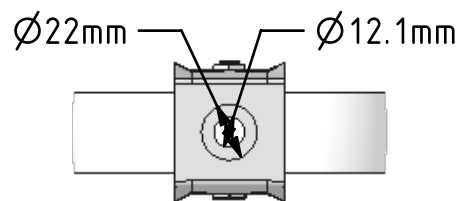
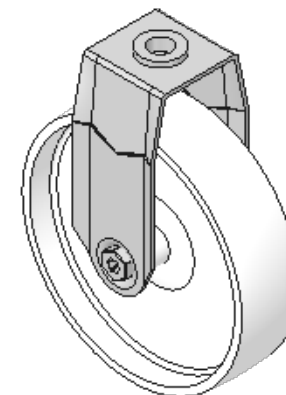

Description:
 BZMF125NYBH12

Pressed steel fixed castor with a 12mm bolt hole fitted with a white nylon wheel with plain bore. Wheel diameter 125mm, tread width 32mm, overall height 156mm, with a Load capacity of 100kg.



	NAME	DATE	 BIL Group Ltd, Porte Marsh Road, Calne Wiltshire, SN11 9BW, United Kingdom Tel +44 (0)1249 822 222 Fax: +44 (0)1249 822 300 www.bilgroup.co.uk
DRAWN	Matt	03/01/18	
APPROVED BY	Tim W	03/01/18	
SCALE	1:3	03/01/18	
WEIGHT	0.372kg	03/01/18	
UNLESS OTHERWISE SPECIFIED DIMENSIONS ARE IN MILLIMETRES Unspecified Tolerances Machining ± 0.25mm Fabrication ± 1mm			TITLE BZMF125NYBH12
SIZE	DWG NO.	REV	
A4	BILCW03BZMF125NYBH12_01	1	
FILE NAME	BILCW03BZMF125NYBH12_01.PDF		SHEET 1 OF 1