

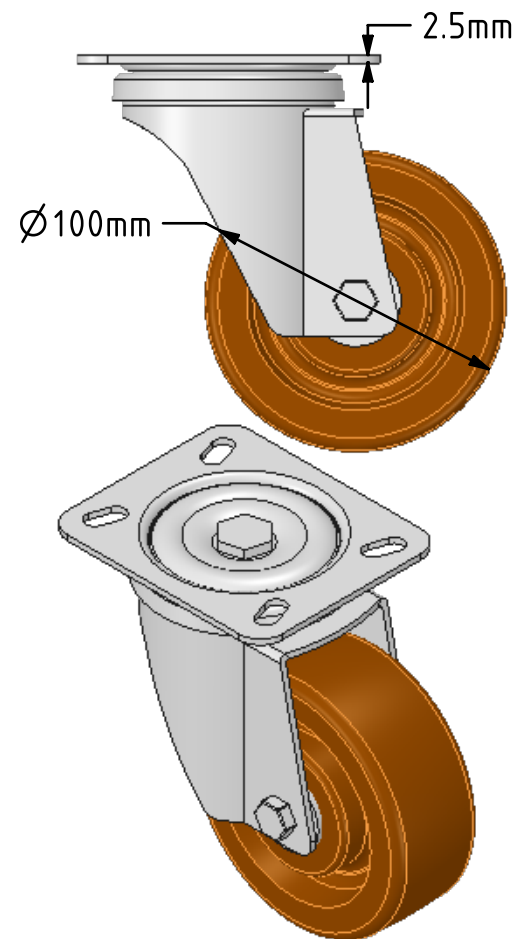

DRAWING DISCLAIMER
 COPYRIGHT OF THIS DRAWING IS RESERVED BY BIL GROUP LTD. IT IS ISSUED ON CONDITION THAT IT IS NOT REPRODUCED, COPIED, OR DISCLOSED TO A THIRD PARTY EITHER WHOLLY OR IN PART WITHOUT THE CONSENT IN WRITING OF BIL GROUP LTD.

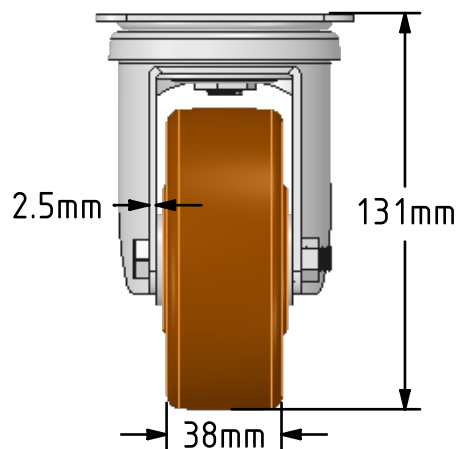
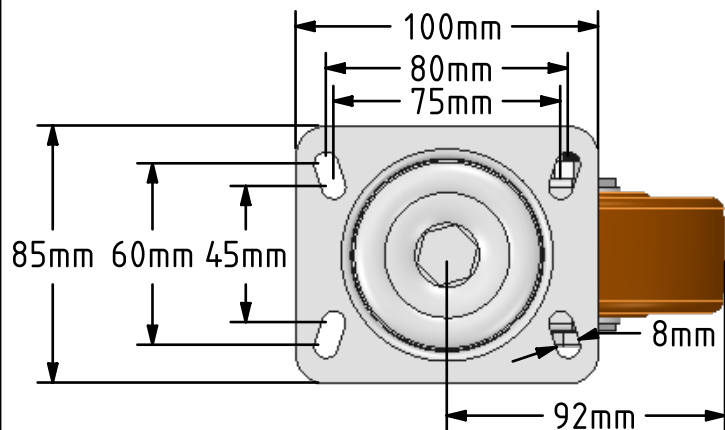

Description:
 BZMH100ANHT

Pressed steel swivel castor with a top plate fixing fitted with a brown phenolic wheel. Wheel diameter 100mm, tread width 38mm, overall height 131mm, top plate 100mm x 85mm, hole centres 80mm x 60mm or 75mm x 45mm. Load capacity 180kg with a maximum temperature of 250c..



	NAME	DATE	BIL Group Ltd, Porte Marsh Road, Calne Wiltshire, SN11 9BW, United Kingdom Tel +44 (0)1249 822 222 Fax: +44 (0)1249 822 300 www.bilgroup.co.uk	
DRAWN	Matt	19/03/18	 TITLE BZMH100ANHT	
APPROVED BY	Chris	19/03/18		
SCALE	2:5	19/03/18		
WEIGHT	1.166kg	19/03/18		
UNLESS OTHERWISE SPECIFIED DIMENSIONS ARE IN MILLIMETRES			SIZE	DWG NO.
Unspecified Tolerances Machining ± 0.25mm Fabrication ± 1mm			A4	BILCW03BZMH100ANHT_01
			REV	1
			FILE NAME	BILCW03BZMH100ANHT_01.PDF SHEET 1 OF 1