

DRAWING DISCLAIMER
 COPYRIGHT OF THIS DRAWING IS RESERVED BY BIL GROUP LTD. IT IS ISSUED ON CONDITION THAT IT IS NOT REPRODUCED, COPIED, OR DISCLOSED TO A THIRD PARTY EITHER WHOLLY OR IN PART WITHOUT THE CONSENT IN WRITING OF BIL GROUP LTD.

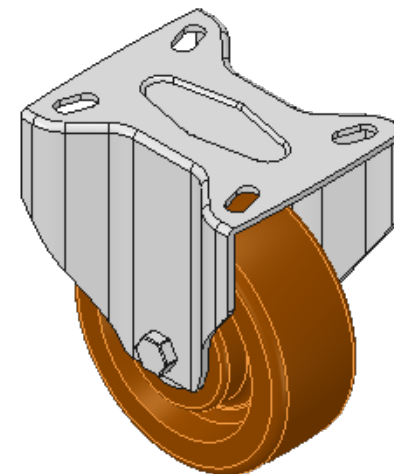

Description:
 BZMHF100ANHT

Pressed steel fixed castor with a top plate fixing fitted with a brown phenolic wheel. Wheel diameter 100mm, tread width 38mm, overall height 131mm, top plate 100mm x 85mm, hole centres 80mm x 60mm or 75mm x 45mm. Load capacity 180kg with a maximum temperature of 250c..

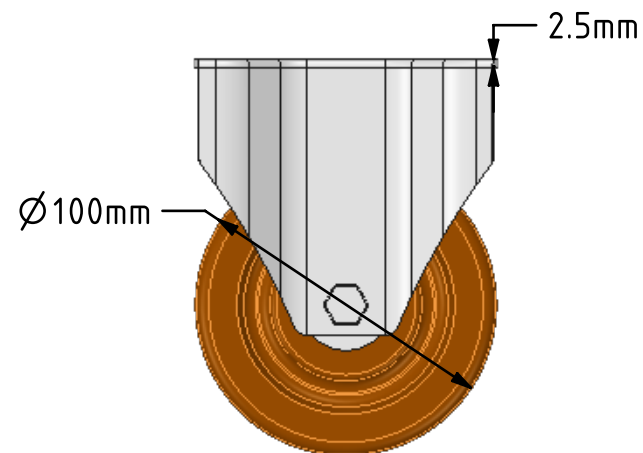
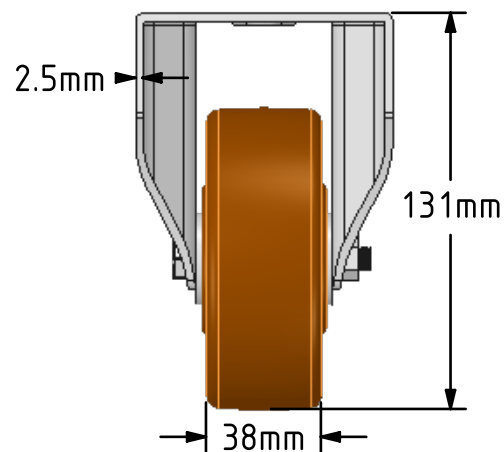
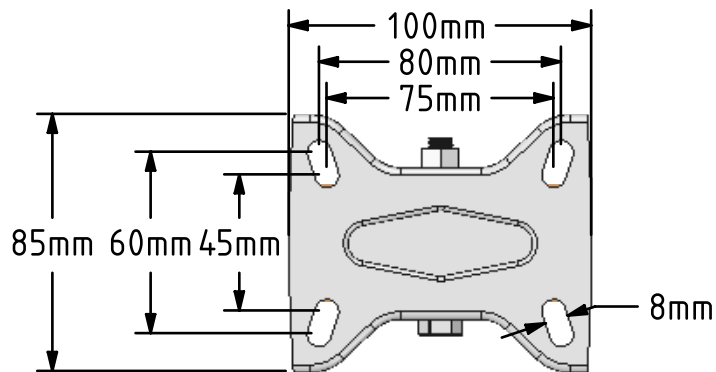
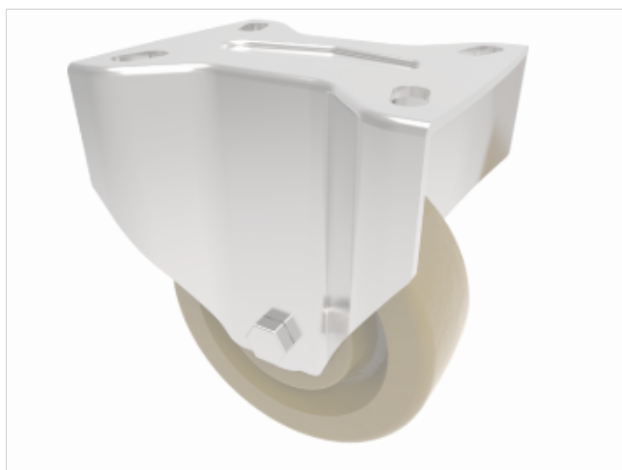

	NAME	DATE
DRAWN	Matt	20/03/18
APPROVED BY	Tim W	20/03/18
SCALE	2:5	20/03/18
WEIGHT	0.862kg	20/03/18

UNLESS OTHERWISE SPECIFIED DIMENSIONS ARE IN MILLIMETRES
 Unspecified Tolerances
 Machining ± 0.25mm
 Fabrication ± 1mm

 BIL Group Ltd, Porte Marsh Road, Calne Wiltshire, SN11 9BW, United Kingdom
 Tel +44 (0)1249 822 222 Fax: +44 (0)1249 822 300
 www.bilgroup.co.uk

TITLE		
BZMHF100ANHT		
SIZE	DWG NO.	REV
A4	BILCW03BZMHF100ANHT__01	1
FILE NAME	BILCW03BZMHF100ANHT__01.PDF SHEET 1 OF 1	