

DRAWING DISCLAIMER
 COPYRIGHT OF THIS DRAWING IS RESERVED BY BIL GROUP LTD. IT IS ISSUED ON CONDITION THAT IT IS NOT REPRODUCED, COPIED, OR DISCLOSED TO A THIRD PARTY EITHER WHOLLY OR IN PART WITHOUT THE CONSENT IN WRITING OF BIL GROUP LTD.

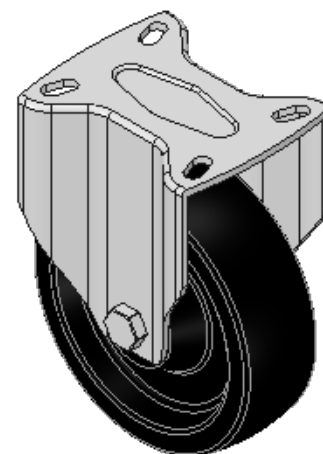

Description:
 BZMHF125AN3

Pressed steel fixed castor with a top plate fixing fitted with a Ditherm wheel with plain bore. Wheel diameter 125mm, tread width 40mm, overall height 158mm, top plate 100mm x 85mm, hole centres 80mm x 60mm or 75mm x 45mm. Load capacity 200kg. 300 C. REACH compliant, RoHS Compliant, USDA approved FDA approved.

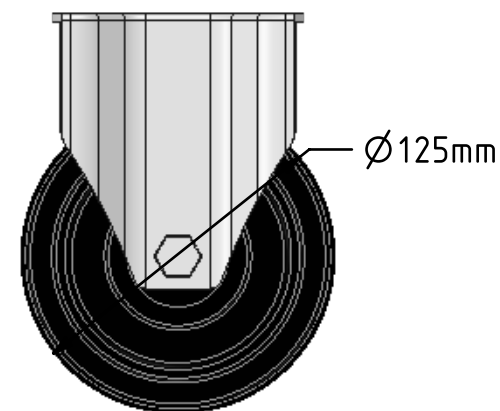
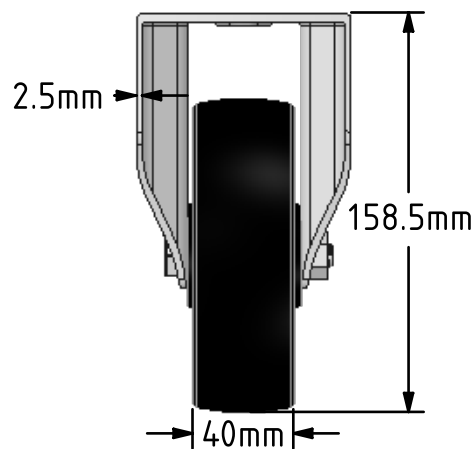
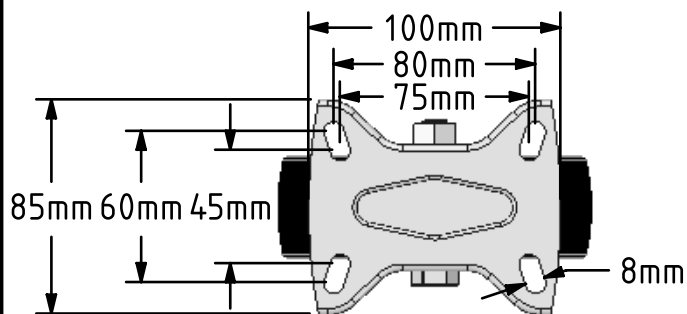
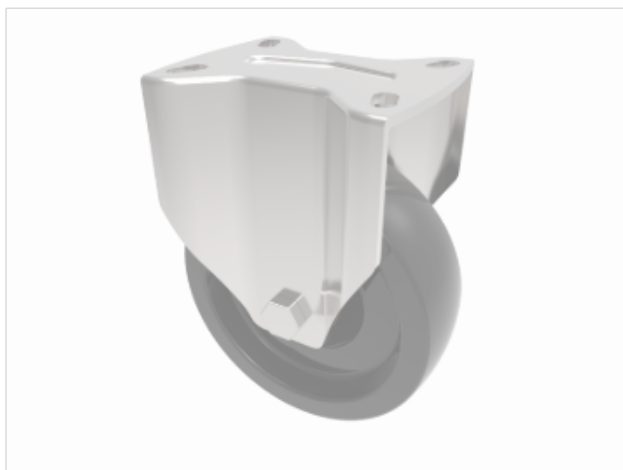

	NAME	DATE
DRAWN	Matt	01/12/17
APPROVED BY	Chris	01/12/17
SCALE	1:3	01/12/17
WEIGHT	1.024kg	01/12/17

UNLESS OTHERWISE SPECIFIED DIMENSIONS ARE IN MILLIMETRES

Unspecified Tolerances
 Machining ± 0.25mm
 Fabrication ± 1mm



BIL Group Ltd, Porte Marsh Road, Calne
 Wiltshire, SN11 9BW, United Kingdom
 Tel +44 (0)1249 822 222 Fax: +44 (0)1249 822 300
 www.bilgroup.co.uk

TITLE

BZMHF125AN3

SIZE DWG NO.
 A4 BILCW03BZMHF125AN3_01

REV
 1

FILE NAME BILCW03BZMHF125AN3_01.PDF SHEET 1 OF 1