

DRAWING DISCLAIMER
 COPYRIGHT OF THIS DRAWING IS RESERVED BY BIL GROUP LTD. IT IS ISSUED ON CONDITION THAT IT IS NOT REPRODUCED, COPIED, OR DISCLOSED TO A THIRD PARTY EITHER WHOLLY OR IN PART WITHOUT THE CONSENT IN WRITING OF BIL GROUP LTD.

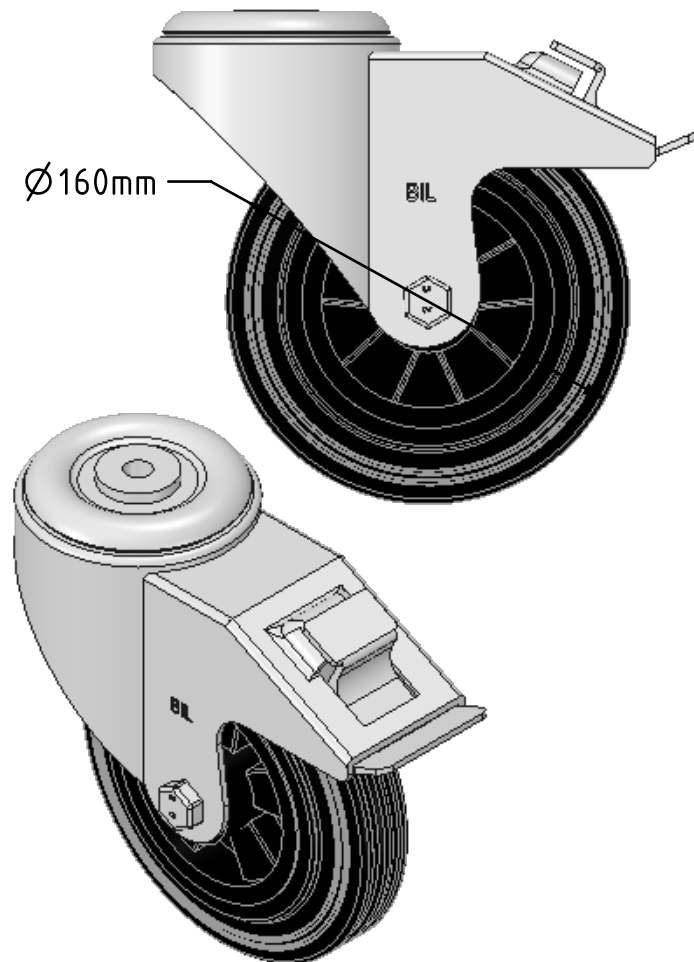

Description:
 BZMM160PSBBH12SWB

Pressed steel swivel castor with a 12mm bolt hole fitted with a black rubber tyre black polypropylene centred wheel with a roller bearing and a total lock brake. Wheel diameter 160mm, tread width 40mm, overall height 195mm, Load capacity 140kg.

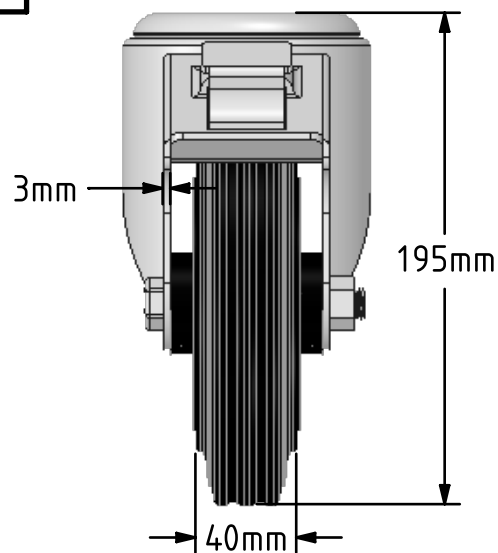
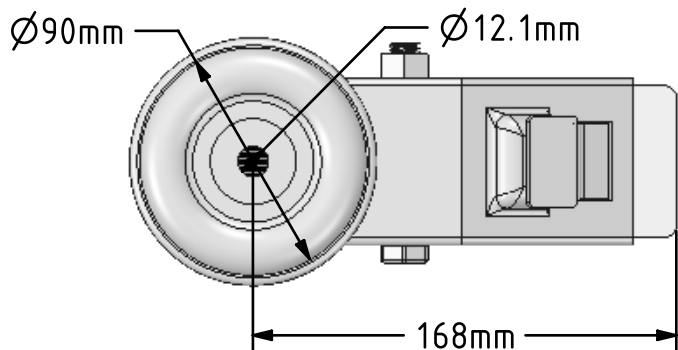

	NAME	DATE
DRAWN	Matt	13/07/18
APPROVED BY	Chris	13/07/18
SCALE	1:3	13/07/18
WEIGHT	2.506kg	13/07/18

UNLESS OTHERWISE SPECIFIED DIMENSIONS ARE IN MILLIMETRES

Unspecified Tolerances
 Machining ± 0.25mm
 Fabrication ± 1mm



BIL Group Ltd, Porte Marsh Road, Calne
 Wiltshire, SN11 9BW, United Kingdom
 Tel +44 (0)1249 822 222 Fax: +44 (0)1249 822 300
 www.bilgroup.co.uk

TITLE

BZMM160PSBBH12SWB

SIZE	DWG NO.	REV
A4	BILCW03BZMM160PSBBH12SWB_01	1

FILE NAME BILCW03BZMM160PSBBH12SWB_01.PDF SHEET 1 OF 1