

DRAWING DISCLAIMER
 COPYRIGHT OF THIS DRAWING IS RESERVED BY BIL GROUP LTD. IT IS ISSUED ON CONDITION THAT IT IS NOT REPRODUCED, COPIED, OR DISCLOSED TO A THIRD PARTY EITHER WHOLLY OR IN PART WITHOUT THE CONSENT IN WRITING OF BIL GROUP LTD.

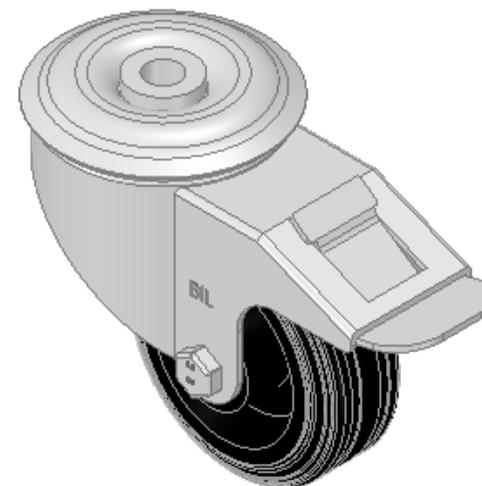

Description:
 BZMM80PSBBH12SWB

Pressed steel swivel castor with 12mm bolt hole fixing fitted with a black rubber tyre black polypropylene centred wheel with roller bearing and total lock brake. Wheel diameter 80mm, Tread width 29mm, overall height 105mm. Load capacity 50kg.

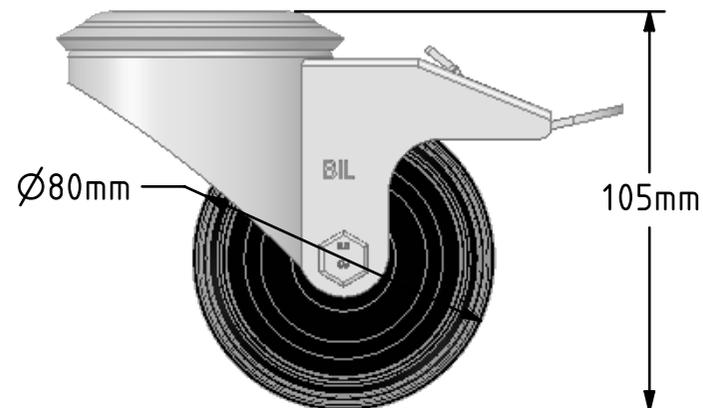
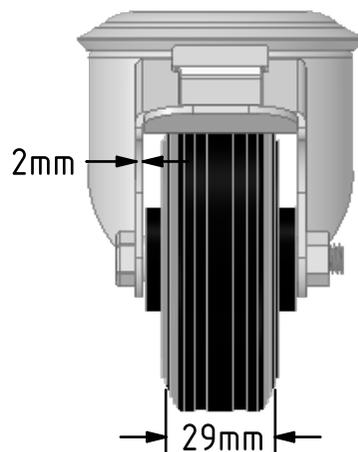
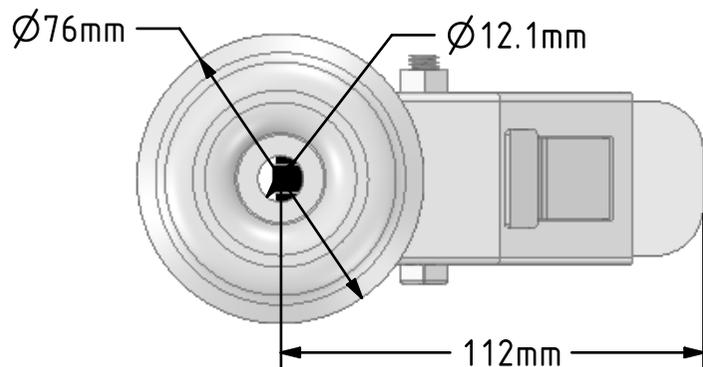

	NAME	DATE
DRAWN	Matt	17/08/18
APPROVED BY	Kevin	17/08/18
SCALE	1:2	17/08/18
WEIGHT	0.738kg	17/08/18

UNLESS OTHERWISE SPECIFIED DIMENSIONS ARE IN MILLIMETRES

Unspecified Tolerances
 Machining ± 0.25mm
 Fabrication ± 1mm



BIL Group Ltd, Porte Marsh Road, Calne
 Wiltshire, SN11 9BW, United Kingdom
 Tel +44 (0)1249 822 222 Fax: +44 (0)1249 822 300
 www.bilgroup.co.uk

TITLE

BZMM80PSBBH12SWB

SIZE	DWG NO.	REV
A4	BILCW03BZMM80PSBBH12SWB__01	1

FILE NAME BILCW03BZMM80PSBBH12SWB__01.PDF SHEET 1 OF 1