

DRAWING DISCLAIMER
 COPYRIGHT OF THIS DRAWING IS RESERVED BY BIL GROUP LTD. IT IS ISSUED ON CONDITION THAT IT IS NOT REPRODUCED, COPIED, OR DISCLOSED TO A THIRD PARTY EITHER WHOLLY OR IN PART WITHOUT THE CONSENT IN WRITING OF BIL GROUP LTD.

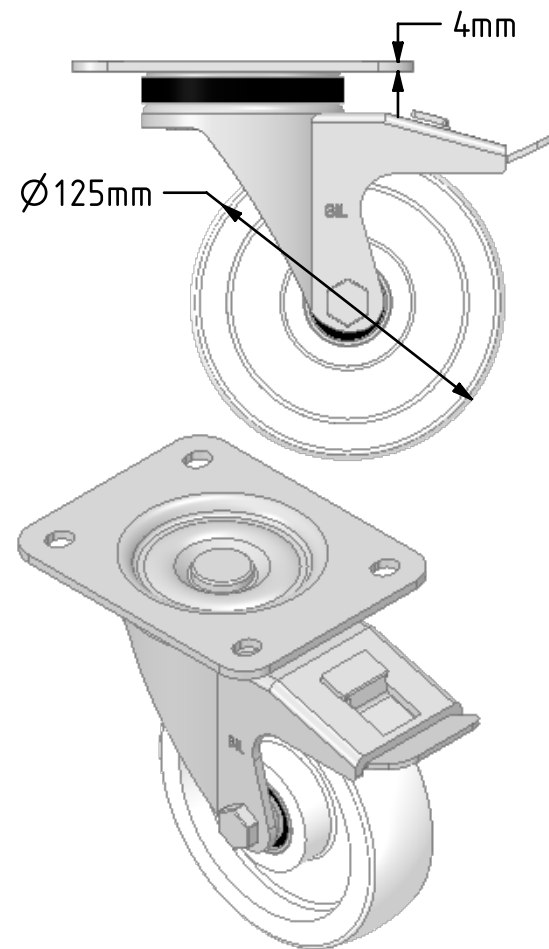

Description:
 BZPH125NYBJSWB

Pressed steel swivel castor, fitted with a top plate and a white nylon wheel with ball bearings and a total lock brake. Wheel diameter 125mm, tread width 35mm, overall height 158mm top plate 135 x 110mm, bolt holes 105 x 80/75mm with a load capacity of 500kg

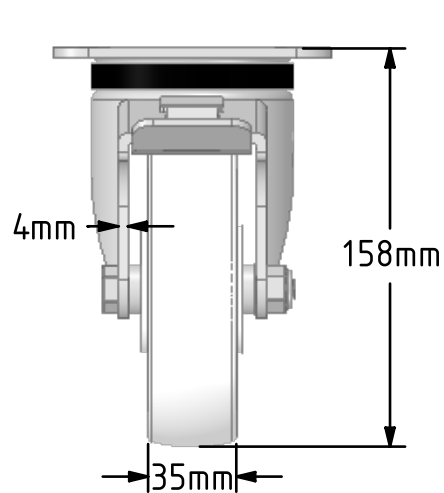
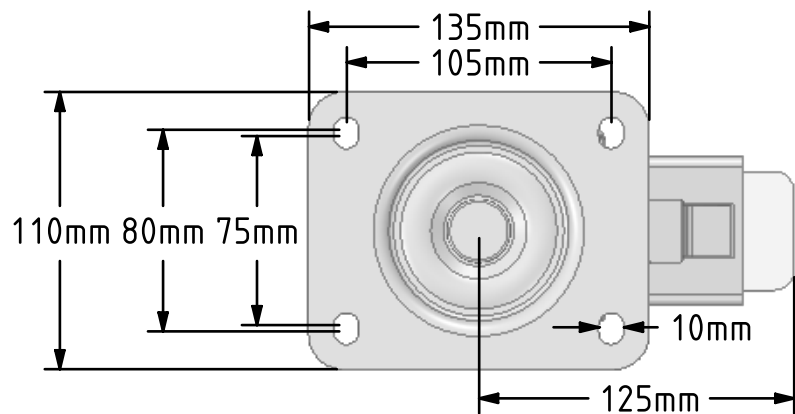

	NAME	DATE
DRAWN	Matt	01/11/18
APPROVED BY	Chris	01/11/18
SCALE	1:3	01/11/18
WEIGHT	1.633kg	01/11/18

 BIL Group Ltd, Porte Marsh Road, Calne
 Wiltshire, SN11 9BW, United Kingdom
 Tel +44 (0)1249 822 222 Fax: +44 (0)1249 822 300
 www.bilgroup.co.uk

TITLE	BZPH125NYBJSWB	
-------	----------------	--

UNLESS OTHERWISE SPECIFIED DIMENSIONS ARE IN MILLIMETRES
 Unspecified Tolerances
 Machining ± 0.25mm
 Fabrication ± 1mm

SIZE	DWG NO.	REV
A4	BILCW03BZPH125NYBJSWB__01	1
FILE NAME	BILCW03BZPH125NYBJSWB__01.PDF SHEET 1 OF 1	