

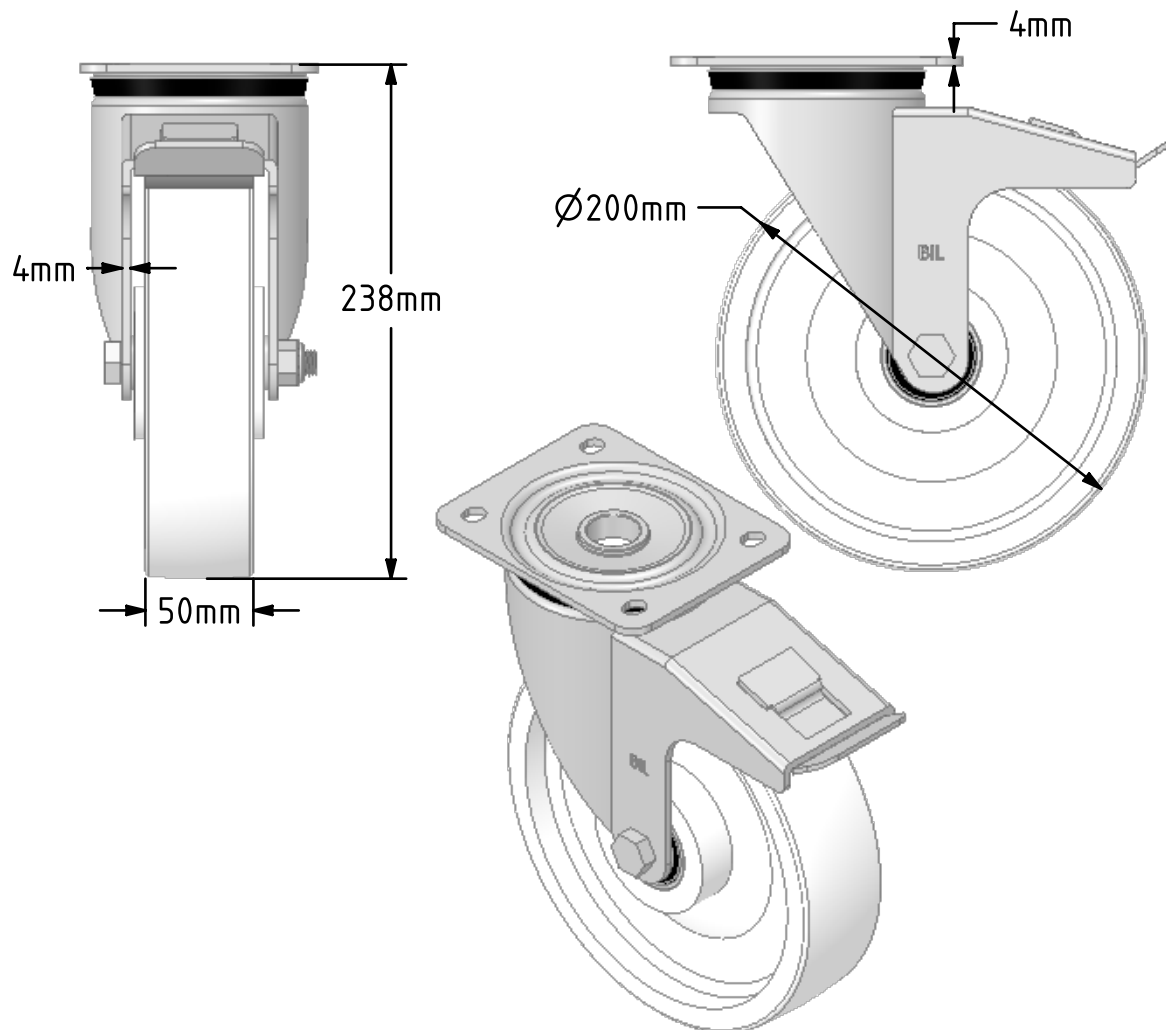

DRAWING DISCLAIMER
 COPYRIGHT OF THIS DRAWING IS RESERVED BY BIL GROUP LTD. IT IS ISSUED ON CONDITION THAT IT IS NOT REPRODUCED, COPIED, OR DISCLOSED TO A THIRD PARTY EITHER WHOLLY OR IN PART WITHOUT THE CONSENT IN WRITING OF BIL GROUP LTD.

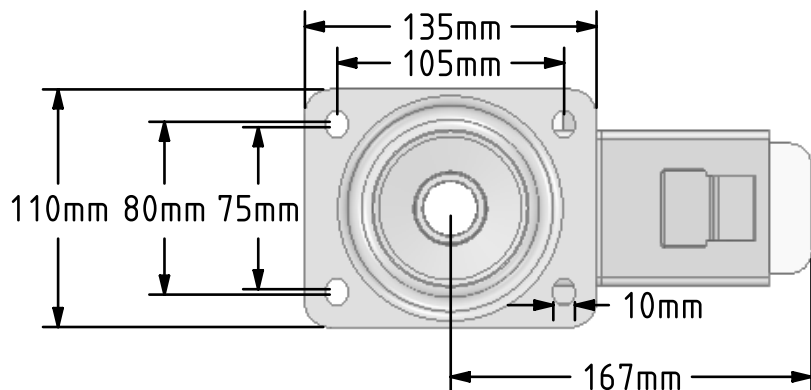

Description:
 BZPH200NYBJSWB

Pressed steel swivel castor with a top plate fixing fitted with a white nylon wheel with ball bearings and total lock brake. Wheel diameter 200mm, tread width 50mm, overall height 238mm, top plate 135mm x 110mm, hole centres 105mm x 80/75mm. Load capacity 500kg.



	NAME	DATE	BIL Group Ltd, Porte Marsh Road, Calne Wiltshire, SN11 9BW, United Kingdom Tel +44 (0)1249 822 222 Fax: +44 (0)1249 822 300 www.bilgroup.co.uk	
DRAWN	Matt	05/11/18	 TITLE BZPH200NYBJSWB	
APPROVED BY	Chris	05/11/18		
SCALE	2:7	05/11/18		
WEIGHT	3.127kg	05/11/18		
UNLESS OTHERWISE SPECIFIED DIMENSIONS ARE IN MILLIMETRES			SIZE	DWG NO.
Unspecified Tolerances Machining ± 0.25mm Fabrication ± 1mm			A4	BILCW03BZPH200NYBJSWB_02
			REV	2
			FILE NAME	BILCW03BZPH200NYBJSWB_02.PDF SHEET 1 OF 1