

**DRAWING DISCLAIMER**  
 COPYRIGHT OF THIS DRAWING IS RESERVED BY BIL GROUP LTD. IT IS ISSUED ON CONDITION THAT IT IS NOT REPRODUCED, COPIED, OR DISCLOSED TO A THIRD PARTY EITHER WHOLLY OR IN PART WITHOUT THE CONSENT IN WRITING OF BIL GROUP LTD.

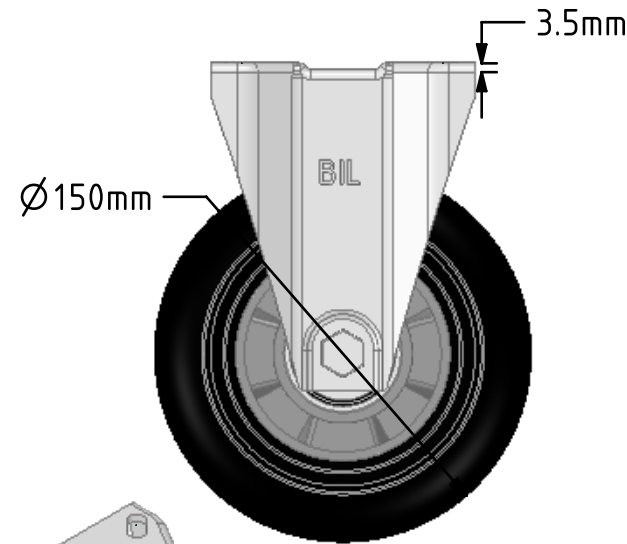

**Description:**  
 BZPHFL150SRERBJ

Pressed steel fixed castor with a top plate fixing fitted with black ergonomic high elastic natural 55 shore A round profile rubber tyre aluminium centred wheel with ball bearings. Wheel diameter 150mm, tread width 47mm, overall height 190mm, top plate 105mm x 86mm, hole centres 80mm x 60mm. Load capacity 270kg. REACH compliant also PAH-Free rubber to confirm to EU-directive 2005/69/EC, also available with flat tread details on request

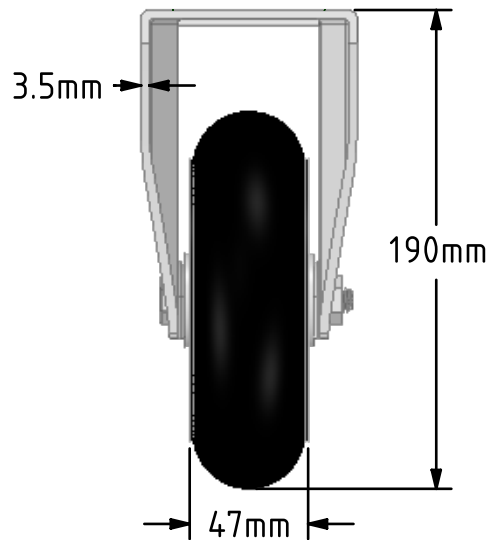
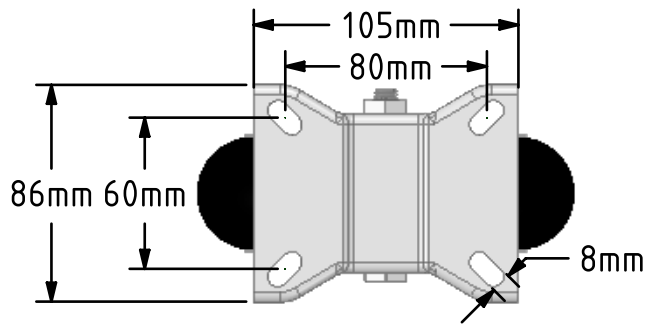

	NAME	DATE
DRAWN	Matt	18/10/18
APPROVED BY	Tim W	18/10/18
SCALE	1:3	18/10/18
WEIGHT	1.813kg	18/10/18

 BIL Group Ltd, Porte Marsh Road, Calne  
 Wiltshire, SN11 9BW, United Kingdom  
 Tel +44 (0)1249 822 222 Fax: +44 (0)1249 822 300  
 www.bilgroup.co.uk

TITLE		
<b>BZPHFL150SRERBJ</b>		

UNLESS OTHERWISE SPECIFIED DIMENSIONS ARE IN MILLIMETRES  
 Unspecified Tolerances  
 Machining ± 0.25mm  
 Fabrication ± 1mm

SIZE	DWG NO.	REV
A4	BILCW03BZPHFL150SRERBJ_01	1
FILE NAME BILCW03BZPHFL150SRERBJ_01.PDF		SHEET 1 OF 1