

DRAWING DISCLAIMER  
 COPYRIGHT OF THIS DRAWING IS RESERVED BY BIL GROUP LTD. IT IS ISSUED ON CONDITION THAT IT IS NOT REPRODUCED, COPIED, OR DISCLOSED TO A THIRD PARTY EITHER WHOLLY OR IN PART WITHOUT THE CONSENT IN WRITING OF BIL GROUP LTD.

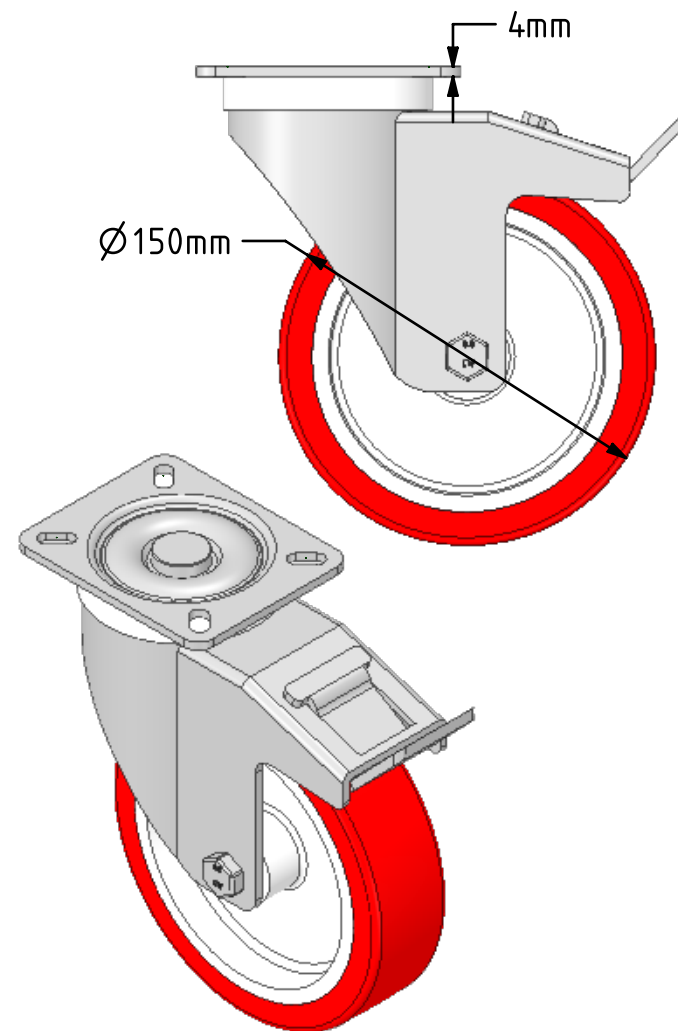

Description:  
 BZPHL150NPSWB

Pressed steel swivel castor with a top plate fixing fitted with a red polyurethane tyre white nylon centred wheel with plain bore and a total lock brake. Wheel diameter 150mm, tread width 40mm, overall height 190mm, top plate 105mm x 86mm, hole centres 80mm x 60mm. Load capacity 350Kg.

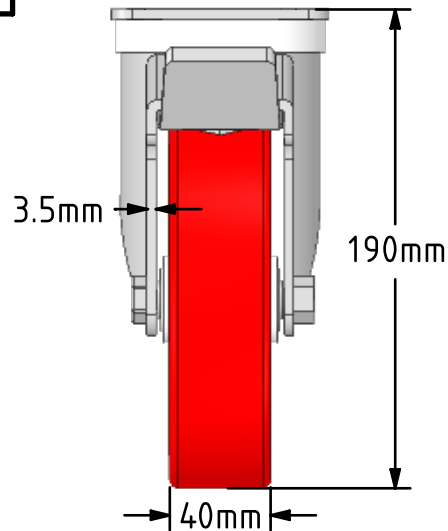
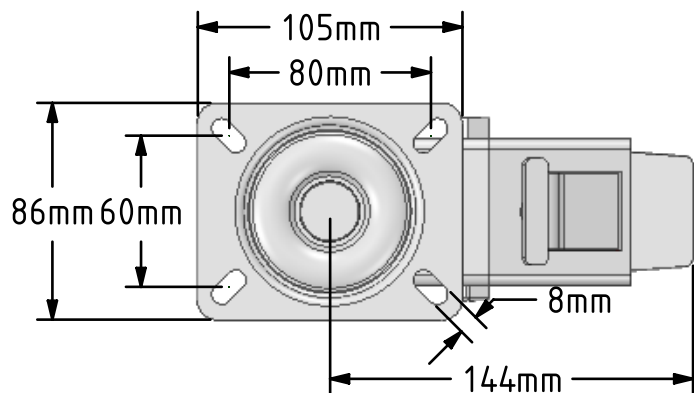

	NAME	DATE
DRAWN	Matt	08/04/19
APPROVED BY	Chris	08/04/19
SCALE	1:3	08/04/19
WEIGHT	1.979kg	08/04/19

UNLESS OTHERWISE SPECIFIED DIMENSIONS ARE IN MILLIMETRES

Unspecified Tolerances  
 Machining ± 0.25mm  
 Fabrication ± 1mm



BIL Group Ltd, Porte Marsh Road, Calne  
 Wiltshire, SN11 9BW, United Kingdom  
 Tel +44 (0)1249 822 222 Fax: +44 (0)1249 822 300  
 www.bilgroup.co.uk

TITLE

BZPHL150NPSWB

SIZE DWG NO.  
 A4 BILCW03BZPHL150NPSWB\_02

REV  
 2

FILE NAME BILCW03BZPHL150NPSWB\_02.PDF SHEET 1 OF 1