

DRAWING DISCLAIMER
 COPYRIGHT OF THIS DRAWING IS RESERVED BY BIL GROUP LTD. IT IS ISSUED ON CONDITION THAT IT IS NOT REPRODUCED, COPIED, OR DISCLOSED TO A THIRD PARTY EITHER WHOLLY OR IN PART WITHOUT THE CONSENT IN WRITING OF BIL GROUP LTD.

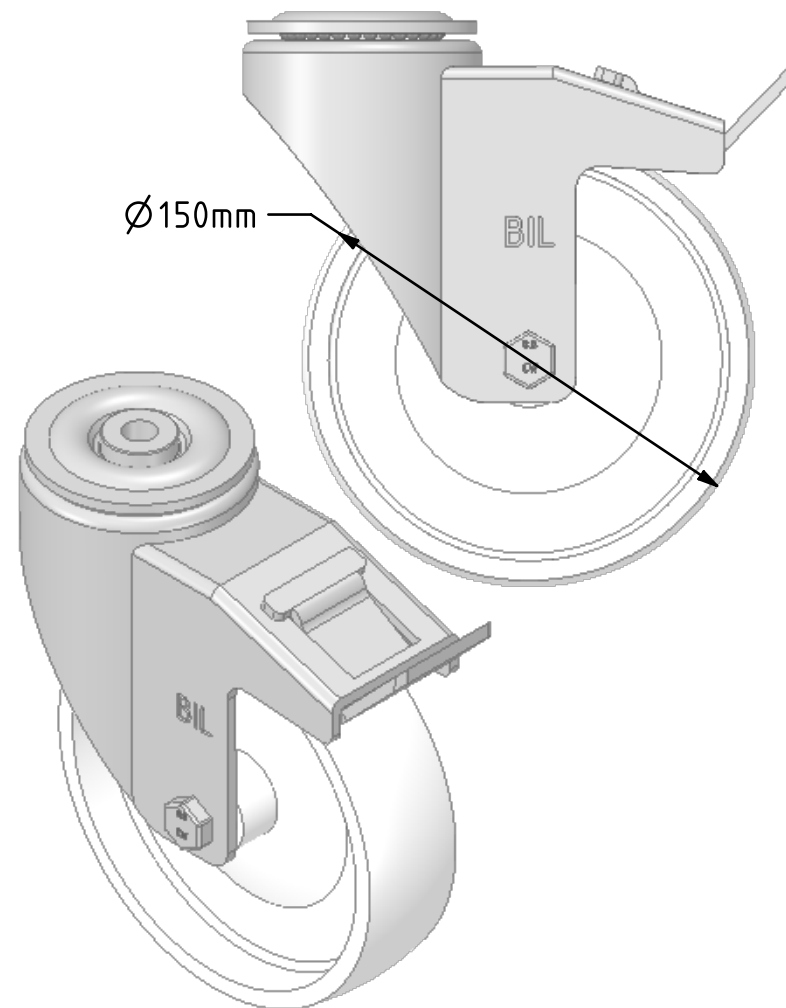

Description:
 BZPHL150NYBBH12SWB

Pressed steel swivel castor with a bolt hole fixing fitted with white nylon wheel with a roller bearing bore. Wheel diameter 150mm, tread width 40mm, overall height 190mm, bolt hole 12mm. Load capacity 300Kg.

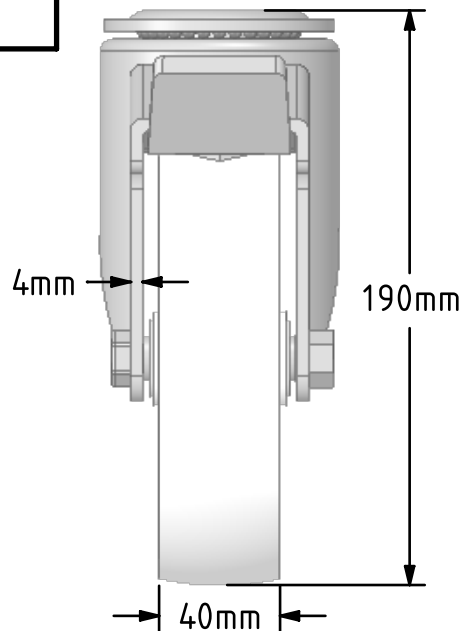
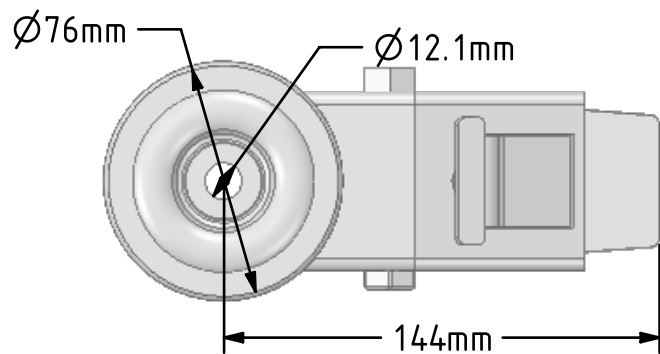

| | NAME | DATE |
|-------------|---------|----------|
| DRAWN | Matt | 24/10/18 |
| APPROVED BY | Tim W | 24/10/18 |
| SCALE | 1:3 | 24/10/18 |
| WEIGHT | 1.632kg | 24/10/18 |

 BIL Group Ltd, Porte Marsh Road, Calne
 Wiltshire, SN11 9BW, United Kingdom
 Tel +44 (0)1249 822 222 Fax: +44 (0)1249 822 300
 www.bilgroup.co.uk

TITLE
BZPHL150NYBBH12SWB

UNLESS OTHERWISE SPECIFIED DIMENSIONS ARE IN MILLIMETRES
 Unspecified Tolerances
 Machining ± 0.25mm
 Fabrication ± 1mm

| SIZE | DWG NO. | REV |
|------|------------------------------|-----|
| A4 | BILCW03BZPHL150NYBBH12SWB_01 | 1 |

FILE NAME BILCW03BZPHL150NYBBH12SWB_01.PDF SHEET 1 OF 1