

DRAWING DISCLAIMER
 COPYRIGHT OF THIS DRAWING IS RESERVED BY BIL GROUP LTD. IT IS ISSUED ON CONDITION THAT IT IS NOT REPRODUCED, COPIED, OR DISCLOSED TO A THIRD PARTY EITHER WHOLLY OR IN PART WITHOUT THE CONSENT IN WRITING OF BIL GROUP LTD.

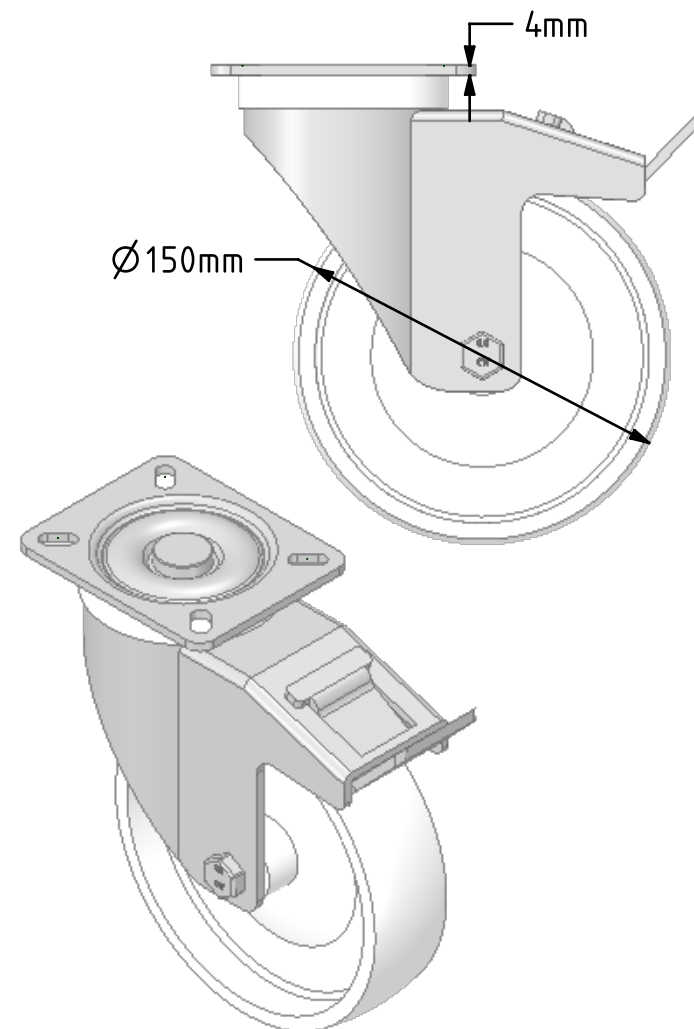

Description:
 BZPHL150NYBSWB

Pressed steel swivel castor with a top plate fixing fitted with white nylon wheel with a roller bearing and a total lock brake. Wheel diameter 150mm, tread width 40mm, overall height 190mm, top plate 105mm x 86mm, hole centres 80mm x 60mm. Load capacity 300Kg.

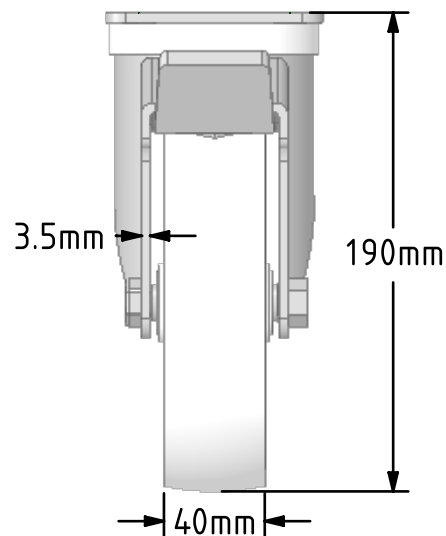
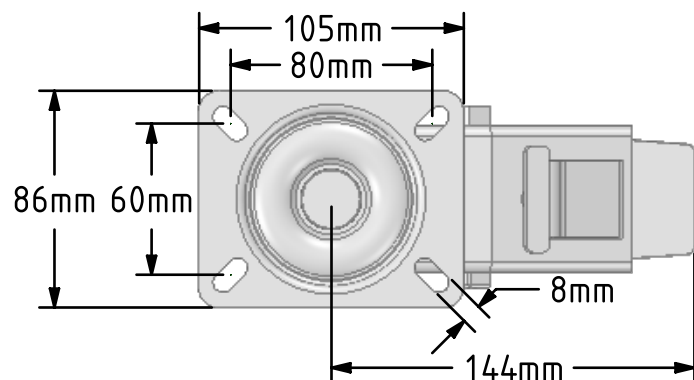

	NAME	DATE
DRAWN	Matt	15/10/18
APPROVED BY	Chris	15/10/18
SCALE	1:3	15/10/18
WEIGHT	1.803kg	15/10/18

BIL Group Ltd, Porte Marsh Road, Calne
 Wiltshire, SN11 9BW, United Kingdom
 Tel +44 (0)1249 822 222 Fax: +44 (0)1249 822 300
 www.bilgroup.co.uk

TITLE		
BZPHL150NYBSWB		
SIZE	DWG NO.	REV
A4	BILCW03BZPHL150NYBSWB_01	1
FILE NAME		SHEET 1 OF 1
BILCW03BZPHL150NYBSWB_01.PDF		

UNLESS OTHERWISE SPECIFIED DIMENSIONS ARE IN MILLIMETRES

Unspecified Tolerances
 Machining ± 0.25mm
 Fabrication ± 1mm