

DRAWING DISCLAIMER
 COPYRIGHT OF THIS DRAWING IS RESERVED BY BIL GROUP LTD. IT IS ISSUED ON CONDITION THAT IT IS NOT REPRODUCED, COPIED, OR DISCLOSED TO A THIRD PARTY EITHER WHOLLY OR IN PART WITHOUT THE CONSENT IN WRITING OF BIL GROUP LTD.

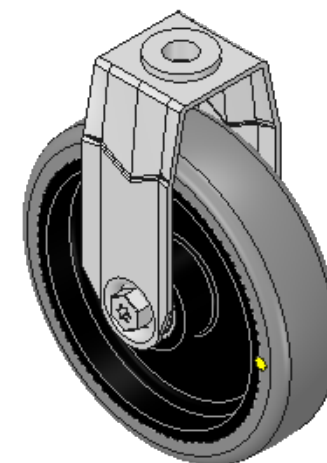

Description:
 BZRAF100GRECBJBH10

Stainless steel fixed castor with a 10mm bolt hole fitted with a non marking grey electrically conductive rubber wheel on a polypropylene centre with a ball bearing. Wheel diameter 100mm, tread width 24mm, overall height 124mm, Load capacity 70kg. Conductive offers a resistance $R < 10K\Omega$

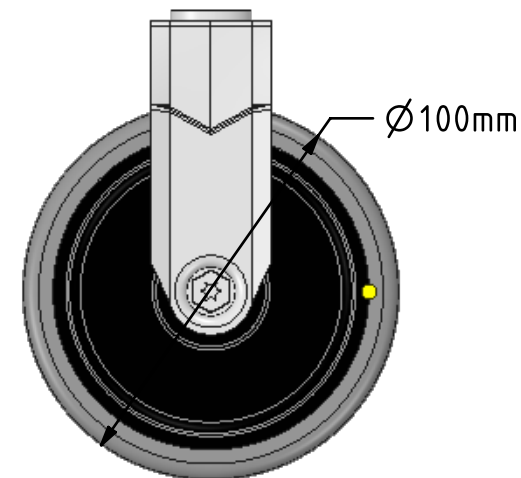
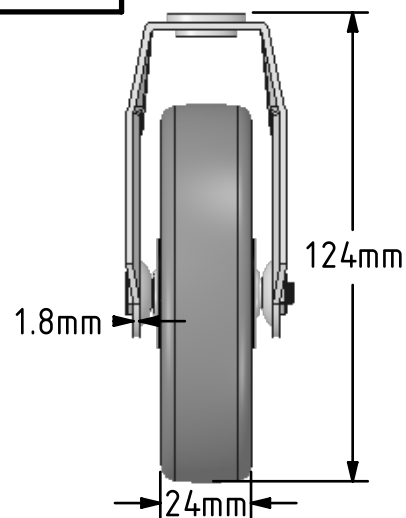
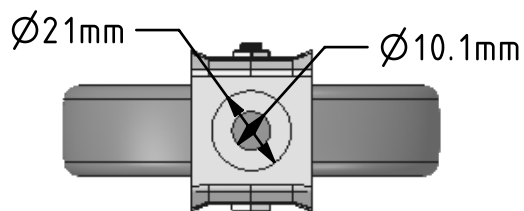

	NAME	DATE
DRAWN	Matt	13/12/17
APPROVED BY	Tim W	13/12/17
SCALE	1:2	13/12/17
WEIGHT	0.233kg	13/12/17

UNLESS OTHERWISE SPECIFIED DIMENSIONS ARE IN MILLIMETRES

Unspecified Tolerances
 Machining $\pm 0.25\text{mm}$
 Fabrication $\pm 1\text{mm}$



BIL Group Ltd, Porte Marsh Road, Calne
 Wiltshire, SN11 9BW, United Kingdom
 Tel +44 (0)1249 822 222 Fax: +44 (0)1249 822 300
 www.bilgroup.co.uk

TITLE

BZRAF100GRECBJBH10

SIZE	DWG NO.	REV
A4	BILCW03BZRAF100GRECBJBH10__01	1

FILE NAME BILCW03BZRAF100GRECBJBH10__01.PDF SHEET 1 OF 1