

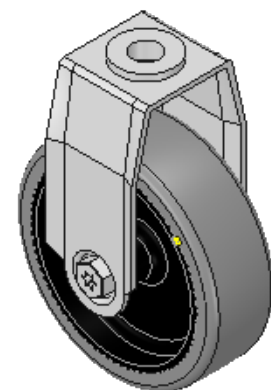

DRAWING DISCLAIMER
 COPYRIGHT OF THIS DRAWING IS RESERVED BY BIL GROUP LTD. IT IS ISSUED ON CONDITION THAT IT IS NOT REPRODUCED, COPIED, OR DISCLOSED TO A THIRD PARTY EITHER WHOLLY OR IN PART WITHOUT THE CONSENT IN WRITING OF BIL GROUP LTD.

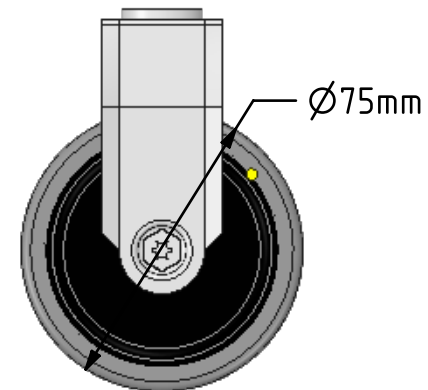
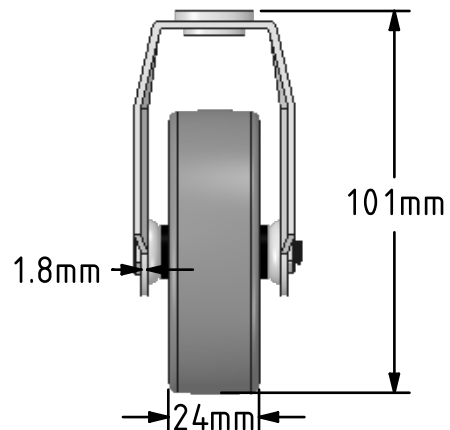
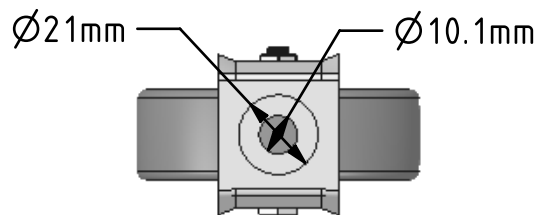

Description:
 BZRAF75GRECBH10

Pressed steel fixed castor with a 10mm bolt hole fitted with a grey electrically conductive rubber tyre on polypropylene centred wheel with a plain bearing. Wheel diameter 75mm, tread width 24mm, overall height 101mm with a Load capacity 60kg. Conductive offers a resistance R<10KΩ



	NAME	DATE	 BIL Group Ltd, Porte Marsh Road, Calne Wiltshire, SN11 9BW, United Kingdom Tel +44 (0)1249 822 222 Fax: +44 (0)1249 822 300 www.bilgroup.co.uk	
DRAWN	Matt	12/12/17	TITLE	
APPROVED BY	Chris	12/12/17	BZRAF75GRECBH10	
SCALE	1:2	12/12/17	SIZE	DWG NO.
WEIGHT	0.149kg	12/12/17	A4	BILCW03BZRAF75GRECBH10__01
UNLESS OTHERWISE SPECIFIED DIMENSIONS ARE IN MILLIMETRES			REV	1
Unspecified Tolerances Machining ± 0.25mm Fabrication ± 1mm			FILE NAME	BILCW03BZRAF75GRECBH10__01.PDF SHEET 1 OF 1