

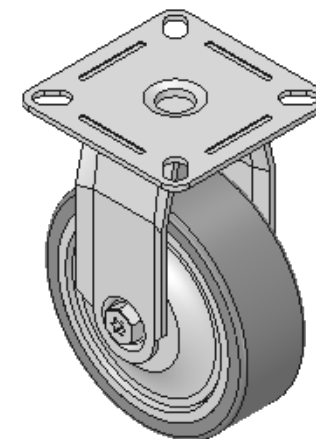

DRAWING DISCLAIMER
 COPYRIGHT OF THIS DRAWING IS RESERVED BY BIL GROUP LTD. IT IS ISSUED ON CONDITION THAT IT IS NOT REPRODUCED, COPIED, OR DISCLOSED TO A THIRD PARTY EITHER WHOLLY OR IN PART WITHOUT THE CONSENT IN WRITING OF BIL GROUP LTD.

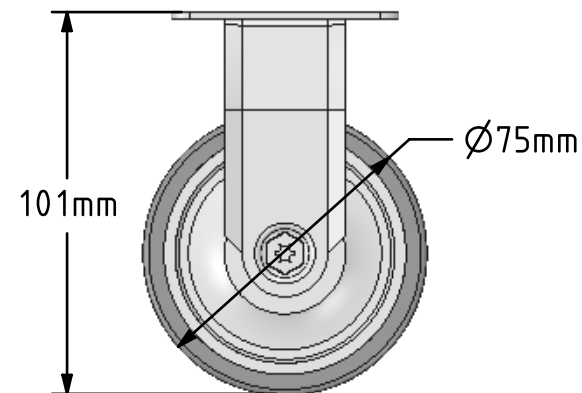
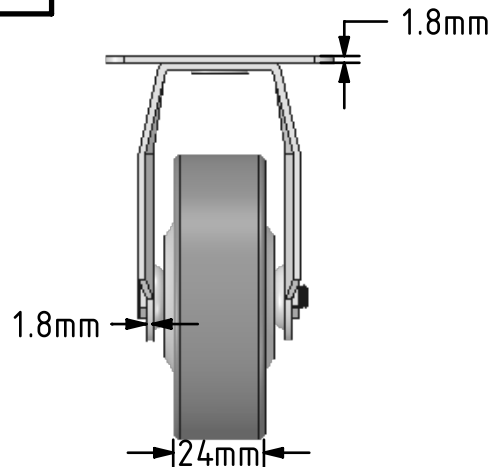
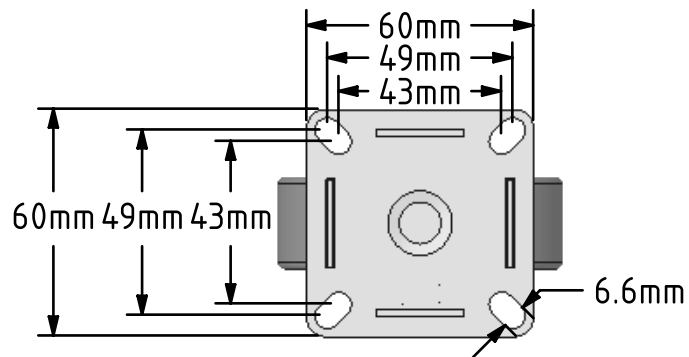

Description:
 BZRAF75VGRBJ

Pressed steel fixed castor with a flat plate fitted with a grey thermoplastic rubber tyre on polypropylene centred wheel with ball bearings. Wheel diameter 75mm, tread width 24mm, overall height 101mm plate size 60mm x 60mm, hole centres 49mm x 49mm or 43mm x 43mm with a Load capacity 50kg.



	NAME	DATE	BIL Group Ltd, Porte Marsh Road, Calne Wiltshire, SN11 9BW, United Kingdom Tel +44 (0)1249 822 222 Fax: +44 (0)1249 822 300 www.bilgroup.co.uk	
DRAWN	Matt	04/12/17		
APPROVED BY	Chris	04/12/17		
SCALE	1:2	04/12/17		
WEIGHT	0.215kg	04/12/17		
UNLESS OTHERWISE SPECIFIED DIMENSIONS ARE IN MILLIMETRES			TITLE	
Unspecified Tolerances Machining ± 0.25mm Fabrication ± 1mm			BZRAF75VGRBJ	
SIZE A4		DWG NO. BILCW03BZRAF75VGRBJ_01	REV 1	
FILE NAME BILCW03BZRAF75VGRBJ_01.PDF			SHEET 1 OF 1	