

DRAWING DISCLAIMER  
 COPYRIGHT OF THIS DRAWING IS RESERVED BY BIL GROUP LTD. IT IS ISSUED ON CONDITION THAT IT IS NOT REPRODUCED, COPIED, OR DISCLOSED TO A THIRD PARTY EITHER WHOLLY OR IN PART WITHOUT THE CONSENT IN WRITING OF BIL GROUP LTD.

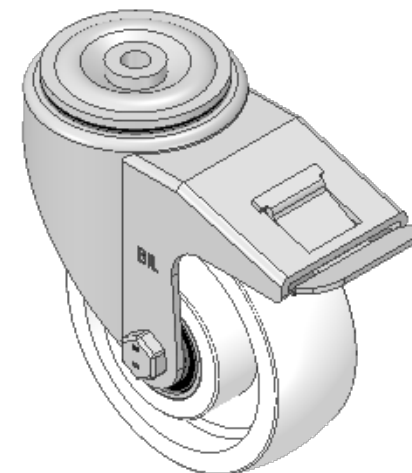

Description:  
 BZWH125NYBJBH12SWB

Pressed steel swivel castor with a 12 mm bolt hole fitted with a white nylon wheel with ball bearings and total lock brake. Wheel diameter 125mm, tread width 45mm, overall height 165mm, Load capacity 400kg.

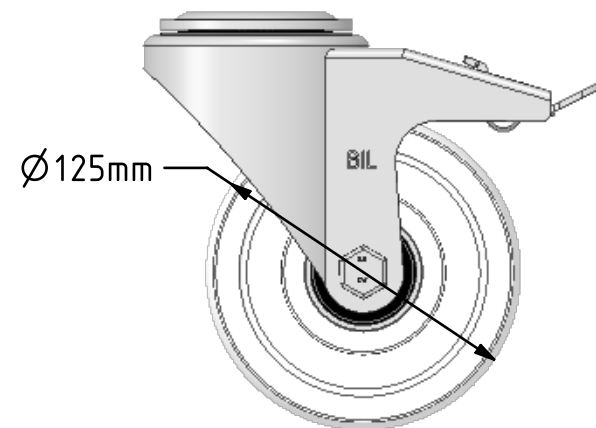
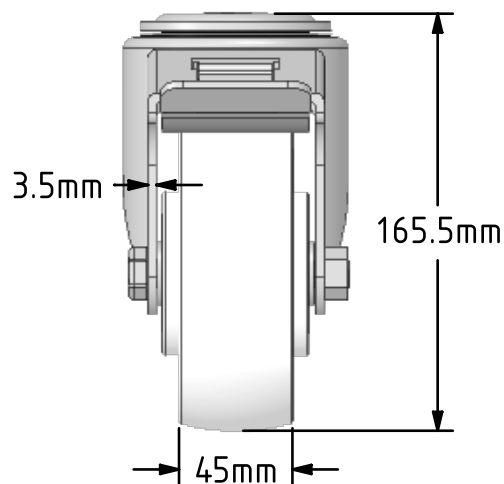
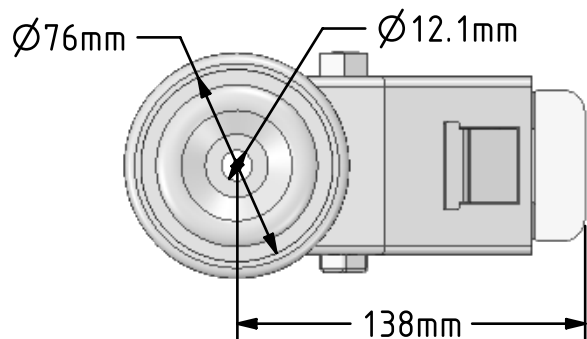

	NAME	DATE
DRAWN	Matt	02/01/19
APPROVED BY	Tim W	02/01/19
SCALE	1:3	02/01/19
WEIGHT	1.834kg	02/01/19

UNLESS OTHERWISE SPECIFIED DIMENSIONS ARE IN MILLIMETRES  
 Unspecified Tolerances  
 Machining ± 0.25mm  
 Fabrication ± 1mm



BIL Group Ltd, Porte Marsh Road, Calne  
 Wiltshire, SN11 9BW, United Kingdom  
 Tel +44 (0)1249 822 222 Fax: +44 (0)1249 822 300  
 www.bilgroup.co.uk

TITLE		
BZWH125NYBJBH12SWB		
SIZE	DWG NO.	REV
A4	BILCW03BZWH125NYBJBH12SWB_01	1
FILE NAME BILCW03BZWH125NYBJBH12SWB_01.PDF SHEET 1 OF 1		