

DRAWING DISCLAIMER
 COPYRIGHT OF THIS DRAWING IS RESERVED BY BIL GROUP LTD. IT IS ISSUED ON CONDITION THAT IT IS NOT REPRODUCED, COPIED, OR DISCLOSED TO A THIRD PARTY EITHER WHOLLY OR IN PART WITHOUT THE CONSENT IN WRITING OF BIL GROUP LTD.

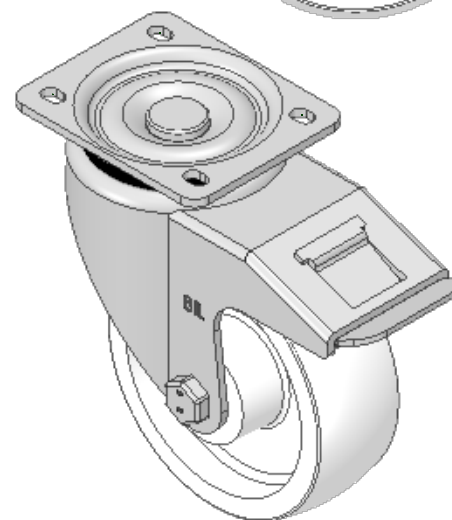

Description:
 BZWH125NYBSWB

Pressed steel swivel castor with a top plate fixing fitted with a white nylon wheel with roller bearing and total lock brake. Wheel diameter 125mm, tread width 45mm, overall height 165mm, top plate 105mm x 86mm, hole centres 80mm x 60mm. Load capacity 500kg.

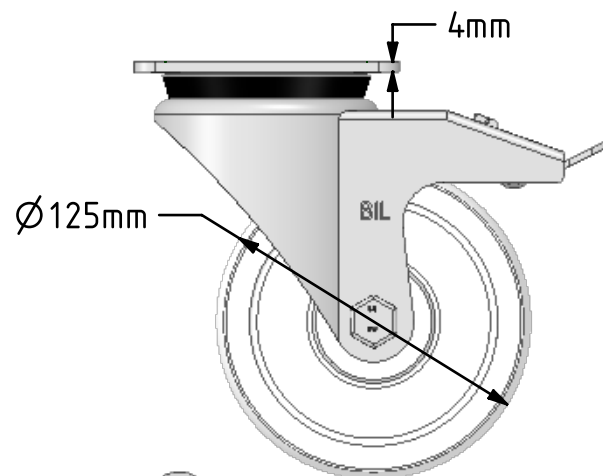
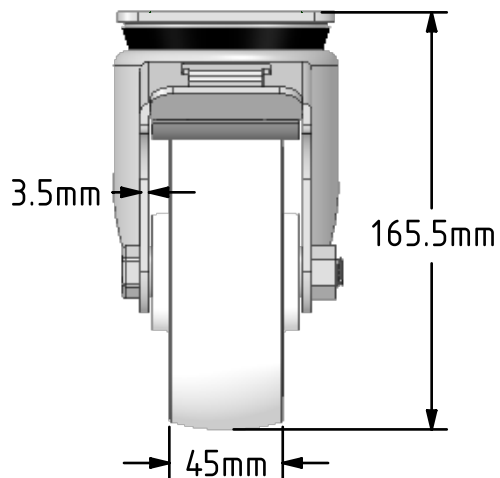
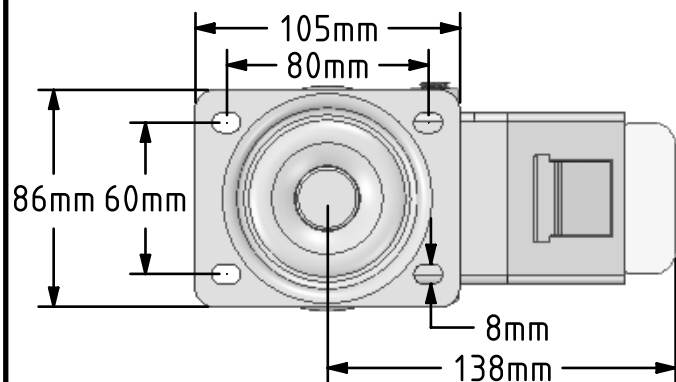

	NAME	DATE
DRAWN	Matt	17/12/18
APPROVED BY	Chris	17/12/18
SCALE	1:3	17/12/18
WEIGHT	1.779kg	17/12/18



BIL Group Ltd, Porte Marsh Road, Calne
 Wiltshire, SN11 9BW, United Kingdom
 Tel +44 (0)1249 822 222 Fax: +44 (0)1249 822 300
 www.bilgroup.co.uk

TITLE

BZWH125NYBSWB

UNLESS OTHERWISE SPECIFIED DIMENSIONS ARE IN MILLIMETRES
 Unspecified Tolerances
 Machining ± 0.25mm
 Fabrication ± 1mm

SIZE	DWG NO.	REV
A4	BILCW03BZWH125NYBSWB_01	1
FILE NAME BILCW03BZWH125NYBSWB_01.PDF		SHEET 1 OF 1