

DRAWING DISCLAIMER
 COPYRIGHT OF THIS DRAWING IS RESERVED BY BIL GROUP LTD. IT IS ISSUED ON CONDITION THAT IT IS NOT REPRODUCED, COPIED, OR DISCLOSED TO A THIRD PARTY EITHER WHOLLY OR IN PART WITHOUT THE CONSENT IN WRITING OF BIL GROUP LTD.

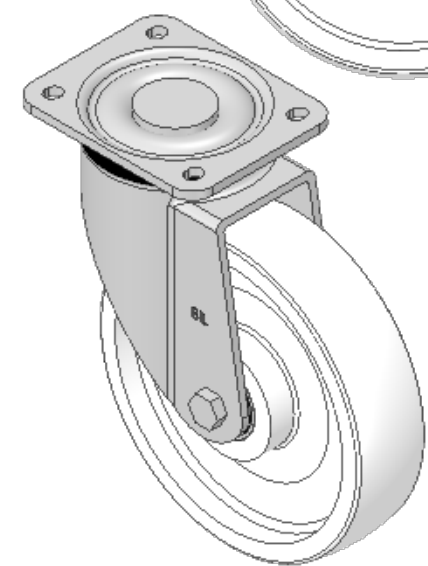

Description:
 BZXP200NYBJ

Pressed steel swivel castor with a top plate fixing fitted with a white nylon wheel with ball bearings. Wheel diameter 200mm, tread width 50mm, overall height 245mm, top plate 135mm x 110mm, hole centres 105mm x 80/75mm. Load capacity 900kg.

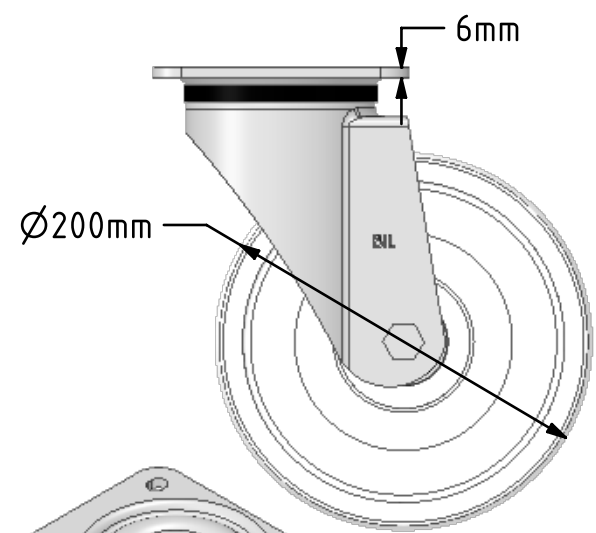
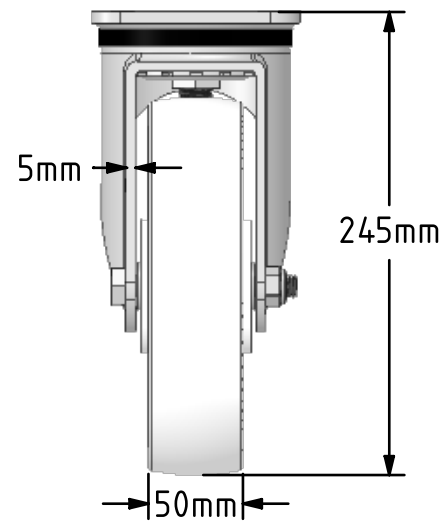
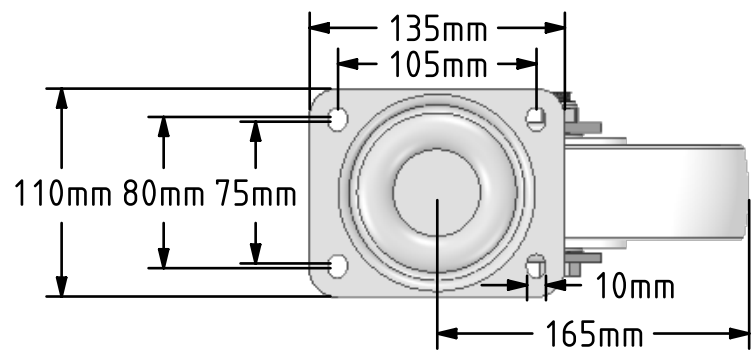

	NAME	DATE
DRAWN	Matt	28/02/19
APPROVED BY	Chris	28/02/19
SCALE	1:4	28/02/19
WEIGHT	3.808kg	28/02/19

UNLESS OTHERWISE SPECIFIED DIMENSIONS ARE IN MILLIMETRES
 Unspecified Tolerances
 Machining ± 0.25mm
 Fabrication ± 1mm

BIL BIL Group Ltd, Porte Marsh Road, Calne Wiltshire, SN11 9BW, United Kingdom
 Tel +44 (0)1249 822 222 Fax: +44 (0)1249 822 300
 www.bilgroup.co.uk

TITLE		REV
BZXP200NYBJ		
SIZE	DWG NO.	REV
A4	BILCW03BZXP200NYBJ_01	1
FILE NAME	BILCW03BZXP200NYBJ_01.PDF SHEET 1 OF 1	