

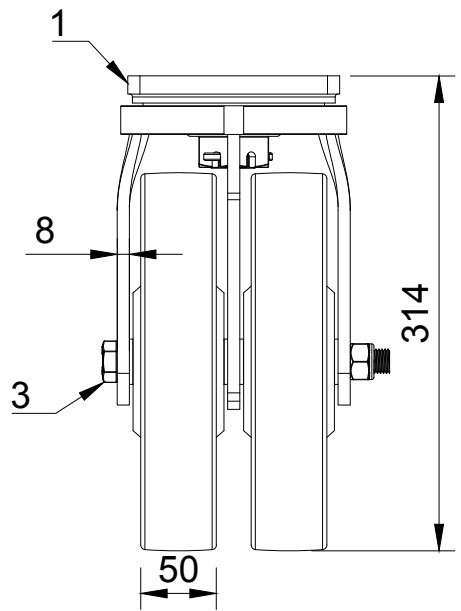

ITEM NO.	PART NUMBER	QTY
1	2BZQ250AS	1
2	BZXH250WNYBJM25HD	2
3	AXLE KIT	
	TH25X3X16	4
	BOLTM16X180Z8.8	1
	NM16NYTHINZ	1



UNLESS OTHERWISE SPECIFIED DIMENSIONS ARE IN MILLIMETRES  Unspecified Tolerances Machining ± 0.25mm Fabrication ± 1mm	DRAWING DISCLAIMER  COPYRIGHT OF THIS DRAWING IS RESERVED BY BIL GROUP LTD. IT IS NOT REPRODUCED, COPIED, OR DISCLOSED TO A THIRD PARTY EITHER WHOLLY OR IN PART WITHOUT THE CONSENT IN WRITING OF BIL GROUP LTD	NAME <b>Matt</b>	DATE <b>20/03/25</b>	 BIL Group Ltd Porte Marsh Road Calne, Wiltshire, SN11 9BW United Kingdom Tel +44 (0)1249 822 222 www.bilgroup.co.uk	 H Varley Ltd Unit 5 Century Park Pacific Rd, Broadheath, Altrincham, Cheshire WA14 5BJ Tel +44 (0)161 928 9617 www.varley-castors.co.uk	
		DRAWN BY <b>Matt</b>	DATE <b>20/03/25</b>			DWG NO. <b>2BZQ250NYBJHD</b>
		APPROVED BY <b>Kevin</b>	DATE <b>20/03/25</b>	<b>2BZQ250NYBJHD</b>		SHEET 1 OF 1
		SCALE <b>1:5</b>	WEIGHT <b>14.065kg</b>			