

| ITEM NO. | PART NUMBER | QTY |
|----------|-----------------|-----|
| 1 | 2BZQXL200AS | 1 |
| 2 | BZXH200WPTBJM25 | 2 |
| 3 | AXLE KIT | |
| | TH25X3X16 | 4 |
| | BOLTM16X180Z8.8 | 1 |
| | NM16NYTHINZ | 1 |

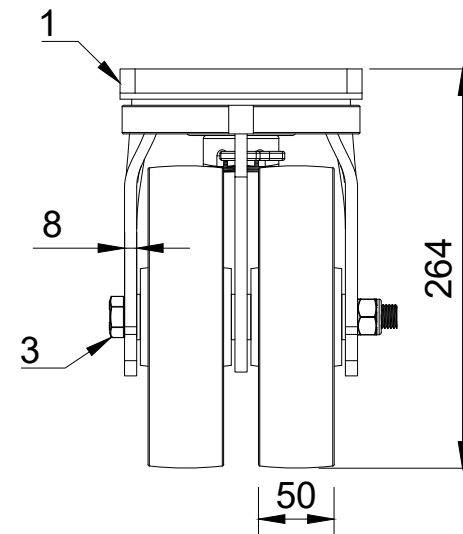

UNLESS OTHERWISE SPECIFIED DIMENSIONS ARE IN MILLIMETRES

Unspecified Tolerances
Machining ± 0.25mm
Fabrication ± 1mm

DRAWING DISCLAIMER

COPYRIGHT OF THIS DRAWING IS RESERVED BY BIL GROUP LTD. IT IS NOT REPRODUCED, COPIED, OR DISCLOSED TO A THIRD PARTY EITHER WHOLLY OR IN PART WITHOUT THE CONSENT IN WRITING OF BIL GROUP LTD

| | NAME | DATE |
|-------------|----------|----------|
| DRAWN BY | Matt | 01/11/24 |
| APPROVED BY | Nathan | 01/11/24 |
| SCALE | 1:5 | |
| WEIGHT | 17.782kg | |

| | | | |
|--|--|------------------|-----|
| <p>BIL Group Ltd Porte Marsh Road Calne, Wiltshire, SN11 9BW United Kingdom Tel +44 (0)1249 822 222 www.bilgroup.co.uk</p> | <p>H Varley Ltd Unit 5 Century Park Pacific Rd, Broadheath, Altrincham, Cheshire WA14 5BJ Tel +44 (0)161 928 9617 www.varley-castors.co.uk</p> | DWG NO. | REV |
| | | 2BZQXL200PTBJ/50 | 1 |
| 2BZQXL200PTBJ/50 | | SHEET 1 OF 1 | |