

ITEM NO.	PART NUMBER	QTY
1	BLKH100ASBH12SWB	1
2	BZH100WSRNRB15/BLK	1
3	AXLE KIT	
	TUBEM15X50/CH	1
	BOLTM10X70BLK	1
	WM10X21X1BLK	2
	NM10STOVERNUT	1

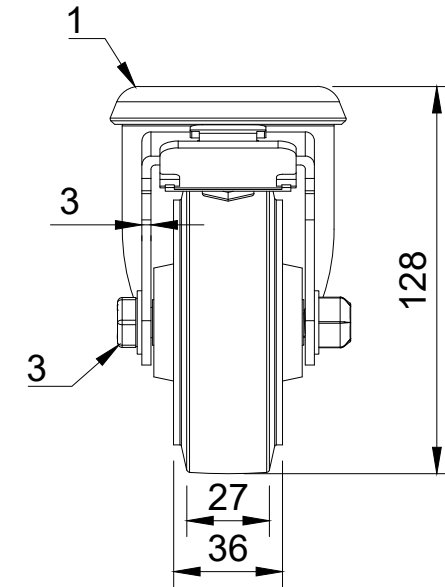

UNLESS OTHERWISE SPECIFIED DIMENSIONS ARE IN MILLIMETRES

Unspecified Tolerances
Machining ± 0.25mm
Fabrication ± 1mm

DRAWING DISCLAIMER

COPYRIGHT OF THIS DRAWING IS RESERVED BY BIL GROUP LTD. IT IS NOT REPRODUCED, COPIED, OR DISCLOSED TO A THIRD PARTY EITHER WHOLLY OR IN PART WITHOUT THE CONSENT IN WRITING OF BIL GROUP LTD

	NAME	DATE
DRAWN BY	Matt	08/05/24
APPROVED BY	Kevin	08/05/24
SCALE	2:5	
WEIGHT	1.061kg	

BIL Group Ltd
Porte Marsh Road
Calne, Wiltshire,
SN11 9BW
United Kingdom
Tel +44 (0)1249 822 222
www.bilgroup.co.uk

H Varley Ltd
Unit 5 Century Park
Pacific Rd, Broadheath,
Altrincham, Cheshire
WA14 5BJ
Tel +44 (0)161 928 9617
www.varley-castors.co.uk

DWG NO. BLKH100SRNBBH12SWB/BLK	REV 1
BLKH100SRNBBH12SWB/BLK SHEET 1 OF 1	