

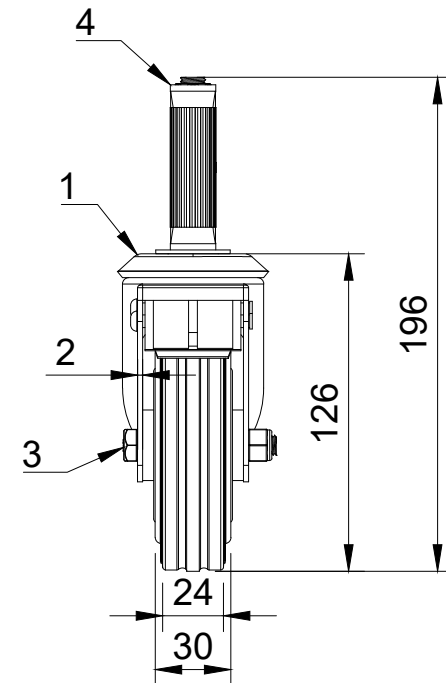

| ITEM NO. | PART NUMBER | QTY |
|----------|------------------|-----|
| 1 | BZBC100ASBH12SWB | 1 |
| 2 | BZMM100WGRRB | 1 |
| 3 | AXLE KIT | |
| | TUBEM12X40 | 1 |
| | HEXBOLTM8X55Z8.8 | 1 |
| | NYLOCM8Z | 1 |
| 4 | BZEXR185/21/SC | 1 |



| | | | | | |
|-----------------------------------------------------------------------------------------------------------------------------------|-------------------------------------------------------------------------------------------------------------------------------------------------------------------------------------------------------------------------------|--------------------|-------------|-------------|--------------------------------------------------------------------------------------------------------------------------------------------------------------------------------------------------------------------------|
| UNLESS OTHERWISE SPECIFIED DIMENSIONS ARE IN MILLIMETRES Unspecified Tolerances Machining ± 0.25mm Fabrication ± 1mm | DRAWING DISCLAIMER COPYRIGHT OF THIS DRAWING IS RESERVED BY BIL GROUP LTD. IT IS NOT REPRODUCED, COPIED, OR DISCLOSED TO A THIRD PARTY EITHER WHOLLY OR IN PART WITHOUT THE CONSENT IN WRITING OF BIL GROUP LTD | | NAME | DATE |  BIL Group Ltd Porte Marsh Road Calne, Wiltshire, SN11 9BW United Kingdom Tel +44 (0)1249 822 222 www.bilgroup.co.uk |
| | | DRAWN BY | Matt | 30/11/23 | |
| | | APPROVED BY | Chris | 30/11/23 | |
| | | SCALE | 1:3 | | |
| | | WEIGHT | 0.845kg | | |
| DWG NO. BZBC100GRBSWBEXR18 | | | | | REV 1 |
| BZBC100GRBSWBEXR18 | | | | | SHEET 1 OF 1 |