

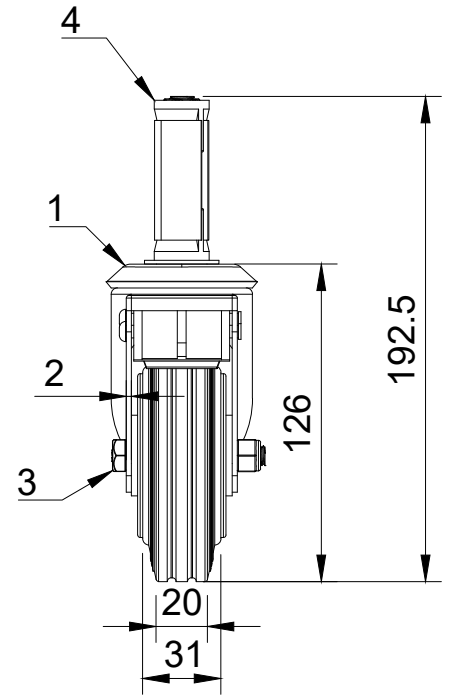

ITEM NO.	PART NUMBER	QTY
1	BZBC100ASBH12SWB	1
2	BZMM100WPSRB	1
3	AXLE KIT	
	TUBEM12X40	1
	HEXBOLTM8X55Z8.8	1
	NYLOCM8Z	1
4	BZEXS215/24/SC	1



UNLESS OTHERWISE SPECIFIED DIMENSIONS ARE IN MILLIMETRES Unspecified Tolerances Machining ± 0.25mm Fabrication ± 1mm	DRAWING DISCLAIMER COPYRIGHT OF THIS DRAWING IS RESERVED BY BIL GROUP LTD. IT IS NOT REPRODUCED, COPIED, OR DISCLOSED TO A THIRD PARTY EITHER WHOLLY OR IN PART WITHOUT THE CONSENT IN WRITING OF BIL GROUP LTD	NAME Matt	DATE 18/01/24	 BIL Group Ltd Porte Marsh Road Calne, Wiltshire, SN11 9BW United Kingdom Tel +44 (0)1249 822 222 www.bilgroup.co.uk	DWG NO. BZBC100PSBSWBEXS21	REV 1
		DRAWN BY Matt	DATE 18/01/24			
		APPROVED BY Kevin	DATE 18/01/24			
		SCALE 1:3				
		WEIGHT 0.795kg				
		BZBC100PSBSWBEXS21		SHEET 1 OF 1		