

| ITEM NO. | PRODUCT NUMBER | QTY |
|----------|------------------|-----|
| 1 | BZBC100ASBH12 | 1 |
| 2 | BZMM100WSRNBJM8 | 1 |
| 3 | AXLE KIT | |
| | HEXBOLTM8X55Z8.8 | 1 |
| | NYLOCM8Z | 1 |

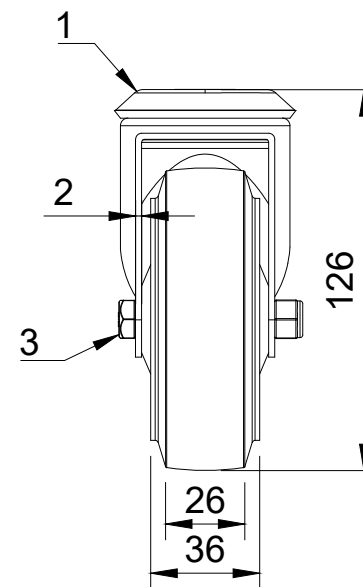

UNLESS OTHERWISE SPECIFIED DIMENSIONS ARE IN MILLIMETRES

Unspecified Tolerances
Machining $\pm 0.25\text{mm}$
Fabrication $\pm 1\text{mm}$

DRAWING DISCLAIMER

COPYRIGHT OF THIS DRAWING IS RESERVED BY BIL GROUP LTD. IT IS NOT REPRODUCED, COPIED, OR DISCLOSED TO A THIRD PARTY EITHER WHOLLY OR IN PART WITHOUT THE CONSENT IN WRITING OF BIL GROUP LTD

| | NAME | DATE |
|-------------|---------|----------|
| DRAWN BY | Matt | 12/10/23 |
| APPROVED BY | Kevin | 12/10/23 |
| SCALE | 2:5 | |
| WEIGHT | 0.575kg | |

BILGroup

BIL Group Ltd
Porte Marsh Road
Calne, Wiltshire, SN11 9BW
United Kingdom
Tel +44 (0)1249 822 222
www.bilgroup.co.uk

DWG NO. **BZBC100SRNBJBH12**

REV **1**

BZBC100SRNBJBH12 SHEET 1 OF 1