

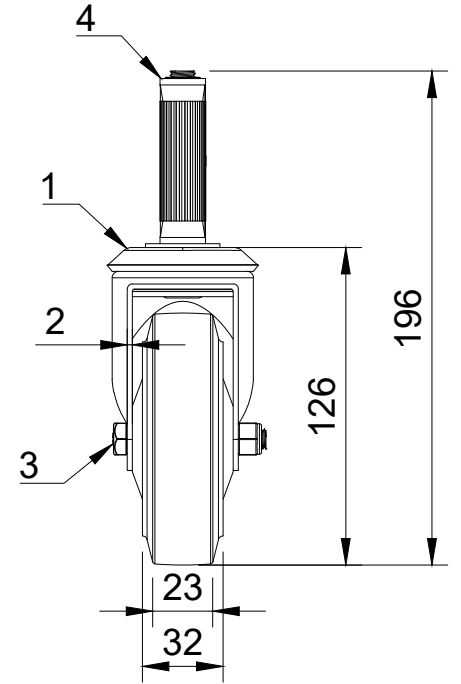

| ITEM NO. | PART NUMBER      | QTY |
|----------|------------------|-----|
| 1        | BZBC100ASBH12    | 1   |
| 2        | BZMM100WSTPRBJM8 | 1   |
| 3        | AXLE KIT         |     |
|          | HEXBOLTM8X55Z8.8 | 1   |
|          | NYLOCM8Z         | 1   |
| 4        | BZEXR185/21/SC   | 1   |



|   |  |             |         |  |                                      |                 |          |
|---|--|-------------|---------|--|--------------------------------------|-----------------|----------|
| UNLESS OTHERWISE SPECIFIED DIMENSIONS ARE IN MILLIMETRES<br><br>Unspecified Tolerances<br>Machining ± 0.25mm<br>Fabrication ± 1mm | DRAWING DISCLAIMER<br><br>COPYRIGHT OF THIS DRAWING IS RESERVED BY BIL GROUP LTD. IT IS NOT REPRODUCED, COPIED, OR DISCLOSED TO A THIRD PARTY EITHER WHOLLY OR IN PART WITHOUT THE CONSENT IN WRITING OF BIL GROUP LTD | NAME        | DATE    |  BIL Group Ltd<br>Porte Marsh Road<br>Calne, Wiltshire, SN11 9BW<br>United Kingdom<br>Tel +44 (0)1249 822 222<br>www.bilgroup.co.uk | DWG NO.<br><b>BZBC100STPRBJEXR18</b> | REV<br><b>1</b> |          |
|   |  | DRAWN BY    | Matt    |  |                                      |                 | 29/11/23 |
|   |  | APPROVED BY | Chris   |  |                                      |                 | 29/11/23 |
|   |  | SCALE       | 1:3     |  |                                      |                 |          |
|   |  | WEIGHT      | 0.607kg |  |                                      |                 |          |
|   |  |             |         | BZBC100STPRBJEXR18 SHEET 1 OF 1  |                                      |                 |          |