

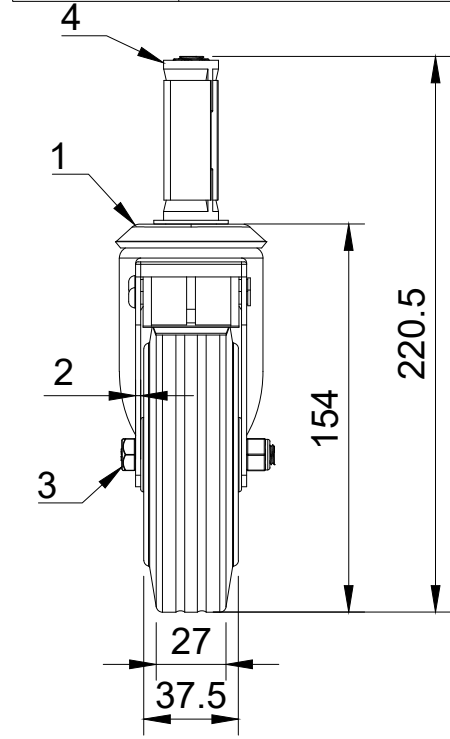

ITEM NO.	PART NUMBER	QTY
1	BZBC125ASBH12SWB	1
2	BZML125WBSRB	1
3	AXLE KIT	
	TUBEM15X40X10	1
	NYLONBUSH	1
	HEXBOLTM8X55Z8.8	1
	NYLOCM8Z	1
4	BZEXS215/24/SC	1



UNLESS OTHERWISE SPECIFIED DIMENSIONS ARE IN MILLIMETRES Unspecified Tolerances Machining ± 0.25mm Fabrication ± 1mm	DRAWING DISCLAIMER COPYRIGHT OF THIS DRAWING IS RESERVED BY BIL GROUP LTD. IT IS NOT REPRODUCED, COPIED, OR DISCLOSED TO A THIRD PARTY EITHER WHOLLY OR IN PART WITHOUT THE CONSENT IN WRITING OF BIL GROUP LTD	NAME	DATE	 BIL Group Ltd Porte Marsh Road Calne, Wiltshire, SN11 9BW United Kingdom Tel +44 (0)1249 822 222 www.bilgroup.co.uk	DWG NO. BZBC125BSBSWBEXS21	REV 1	
		DRAWN BY	Matt				19/01/24
		APPROVED BY	Kevin				19/01/24
		SCALE	1:3				
		WEIGHT	1.201kg				
		BZBC125BSBSWBEXS21		SHEET 1 OF 1			