

21.5 to 24

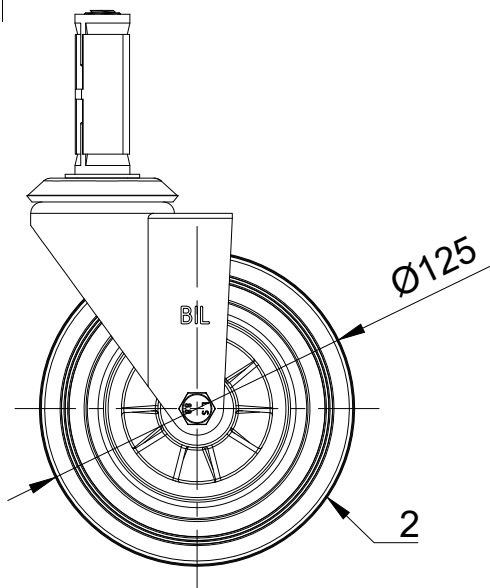

ITEM NO.	PART NUMBER	QTY
1	BZBC125ASBH12	1
2	BZML125WPS12	1
3	AXLE KIT	
	TUBEM12X40	1
	HEXBOLTM8X55Z8.8	1
	NYLOCM8Z	1
4	BZEXS215/24/SC	1

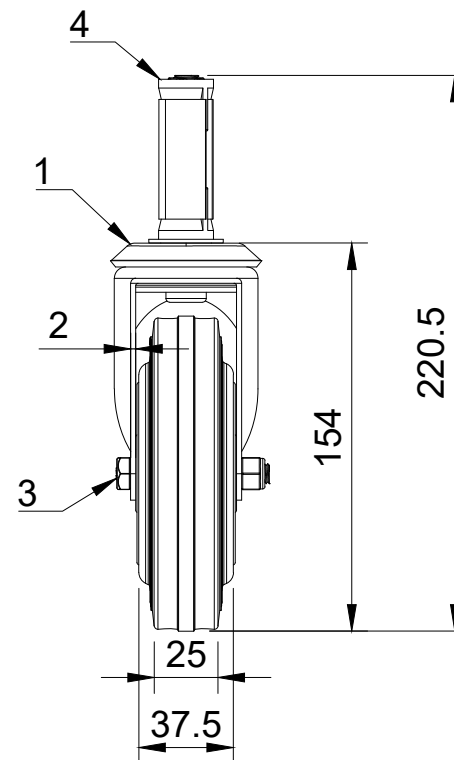

UNLESS OTHERWISE SPECIFIED DIMENSIONS ARE IN MILLIMETRES

Unspecified Tolerances  
Machining ± 0.25mm  
Fabrication ± 1mm

DRAWING DISCLAIMER

COPYRIGHT OF THIS DRAWING IS RESERVED BY BIL GROUP LTD. IT IS NOT REPRODUCED, COPIED, OR DISCLOSED TO A THIRD PARTY EITHER WHOLLY OR IN PART WITHOUT THE CONSENT IN WRITING OF BIL GROUP LTD

	NAME	DATE
DRAWN BY	Matt	19/01/24
APPROVED BY	Kevin	19/01/24
SCALE	1:3	
WEIGHT	0.901kg	

**BILGroup**

BIL Group Ltd  
Porte Marsh Road  
Calne, Wiltshire, SN11 9BW  
United Kingdom  
Tel +44 (0)1249 822 222  
www.bilgroup.co.uk

DWG NO. **BZBC125PSEXS21** REV **1**

**BZBC125PSEXS21** SHEET 1 OF 1