

ITEM NO.	PART NUMBER	QTY
1	BZBC125ASBH12SWB	1
2	BZMM125WSTPRBJM10	1
3	AXLE KIT	
	TUBEM10X37	1
	HEXBOLTM8X55Z8.8	1
	NYLOCM8Z	1
4	BZEXS215/24/SC	1

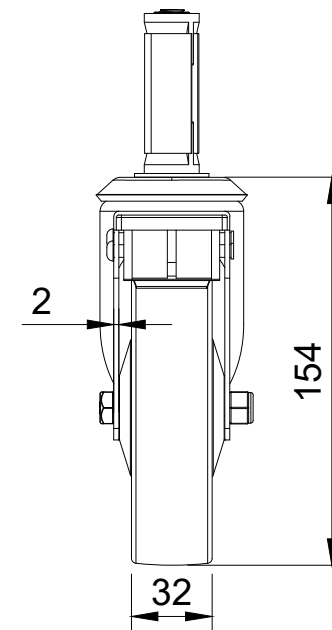

UNLESS OTHERWISE SPECIFIED DIMENSIONS ARE IN MILLIMETRES

Unspecified Tolerances  
Machining  $\pm 0.25\text{mm}$   
Fabrication  $\pm 1\text{mm}$

DRAWING DISCLAIMER

COPYRIGHT OF THIS DRAWING IS RESERVED BY BIL GROUP LTD. IT IS NOT REPRODUCED, COPIED, OR DISCLOSED TO A THIRD PARTY EITHER WHOLLY OR IN PART WITHOUT THE CONSENT IN WRITING OF BIL GROUP LTD

	NAME	DATE
DRAWN BY	Matt	24/10/23
APPROVED BY	Kevin	24/10/23
SCALE	2:5	
WEIGHT	0.798kg	

		BIL Group Ltd Porte Marsh Road Calne, Wiltshire, SN11 9BW United Kingdom Tel +44 (0)1249 822 222 www.bilgroup.co.uk	
		DWG NO.	REV
BZBC125STPRBJSWBEXS21		1	
BZBC125STPRBJSWBEXS21		SHEET 1 OF 1	