

ITEM NO.	PART NUMBER	QTY
1	BZEH100ASBH12SWB	1
2	BZH100WNYRB61	1
3	AXLE KIT	
	TUBEM15X50	1
	HEXBOLTM10X65Z8.8FULL	1
	NYLOCM10Z	1
4	STM20X100	1

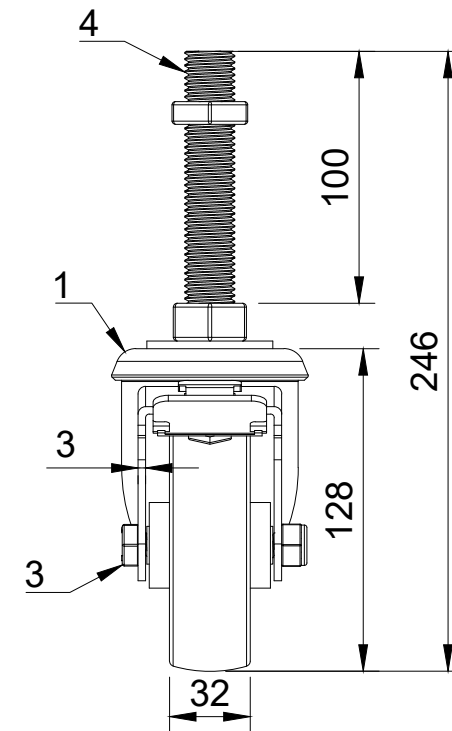

UNLESS OTHERWISE SPECIFIED DIMENSIONS ARE IN MILLIMETRES

Unspecified Tolerances
Machining $\pm 0.25\text{mm}$
Fabrication $\pm 1\text{mm}$

DRAWING DISCLAIMER

COPYRIGHT OF THIS DRAWING IS RESERVED BY BIL GROUP LTD. IT IS NOT REPRODUCED, COPIED, OR DISCLOSED TO A THIRD PARTY EITHER WHOLLY OR IN PART WITHOUT THE CONSENT IN WRITING OF BIL GROUP LTD

	NAME	DATE
DRAWN BY	Matt	03/06/24
APPROVED BY	Kevin	03/06/24
SCALE	1:3	
WEIGHT	1.358kg	

 BIL Group Ltd
 Porte Marsh Road
 Calne, Wiltshire,
 SN11 9BW
 United Kingdom
 Tel +44 (0)1249 822 222
 www.bilgroup.co.uk

 VARLEY
 H Varley Ltd
 Unit 5 Century Park
 Pacific Rd, Broadheath,
 Altrincham, Cheshire
 WA14 5BJ
 Tel +44 (0)161 928 9617
 www.varley-castors.co.uk

DWG NO. **BZEH100NYBSWBM20X100** REV **1**
BZEH100NYBSWBM20X100 SHEET 1 OF 1